

TOSTEM

TOSTEM

FRAMING THE
BEAUTY OF LIVING

PRODUCT COLLECTION 2022

PRODUCT COLLECTION

TOSTEM

Contact us:
LIXIL Window Systems Private Limited Corp.
Office: Plot No. 75, Sector 8, IMT Manesar,
Gurgaon, Haryana, India-122050
E-mail: support.lwsindia@lixil.com
Customer Care Toll Free No: 18001036855
Website: www.tostemindia.com

Channel Partner
ZACKLE
+91 9746 47 07 67

PART OF **LIXIL**

2022 | 1

TABLE OF CONTENTS

| | |
|------------------------------------|---------|
| CORPORATE PROFILE | 002-003 |
| TOSTEM BRAND | 004-005 |
| FRAMING THE BEAUTY OF LIVING | 006-007 |
| TOSTEM BUSINESS HISTORY | 008-009 |
| PRE-ENGINEERED SYSTEM | 010-011 |
| TOSTEM TRUST | 012-013 |
| JAPANESE ENGINEERING | 014-015 |
| TOSTEM TOTAL HOUSING SOLUTION | 016-017 |
| COLOR PROCESSING | 018-019 |
| L-FIT DESIGN | 020-021 |
| QUALITY ASSURANCE | 022-023 |
| WHY PERFORMANCE IS IMPORTANT TO US | 024-025 |
| TOSTEM AIRFLOW SYSTEM | 026-027 |
| TOSTEM WINDOW AND DOOR SERIES | 028-029 |
| INDEX | 030-033 |
| GRANTS SERIES | 034-045 |
| ATIS SERIES | 046-065 |
| WE SERIES | 066-085 |
| INTERIOR SERIES | 086-091 |
| ENTRANCE DOOR | 092-109 |
| ALUMINUM EXTERIOR | 110-117 |
| PROJECT REFERENCES | 118-119 |
| CONTACT | 120 |



MAKING BETTER HOMES A REALITY FOR EVERYONE, EVERYWHERE

LIXIL GROUP

Every person on the planet dreams of a better home. LIXIL makes that possible with pioneering water and housing products. Born in 2011 through the merger of five of Japan's most successful building materials and housing companies, we draw on our Japanese heritage to create world-leading technology and high-quality products that transform homes. We make things that matter to all sorts of different people, to the many communities we are part of, and to sustainably support the world we live in. Today, our approach comes to life through some of the most trusted global brands in our industry, including TOSTEM, GROHE, American Standard, and INAX. We are proud that our products touch the lives of more than a billion people every day, but believe we have the potential to still do so much more.

TOSTEM

American Standard



INAX



12,000+

PATENTS/DESIGN RIGHTS OWNED

FACTORIES

88 IN **12**

COUNTRIES

EMPLOYEES APPROX.

60,000

\$260 MILLION

R&D INVESTMENT

SHOWROOMS

130 IN **18**

COUNTRIES

PEOPLE USING OUR PRODUCTS:

1 BILLION

TOSTEM BRAND

As the leading Japanese brand for global housing and building materials, TOSTEM stands apart as one that deeply understands the needs of people. TOSTEM's comprehensive range of solutions ensures comfortable home living driven by a simple and seamless user experience. We develop our people-centric home solutions by drawing on a half-century of experience and expertise in balancing design and technology to anticipate the needs of people today and their families for generations to come.



TOSTEM

FRAMING THE BEAUTY OF LIVING

With the harmony of functional performance and aesthetic design, TOSTEM designs to let your nature, experience the harmonious connection of outside and inside.

TOSTEM BUSINESS HISTORY

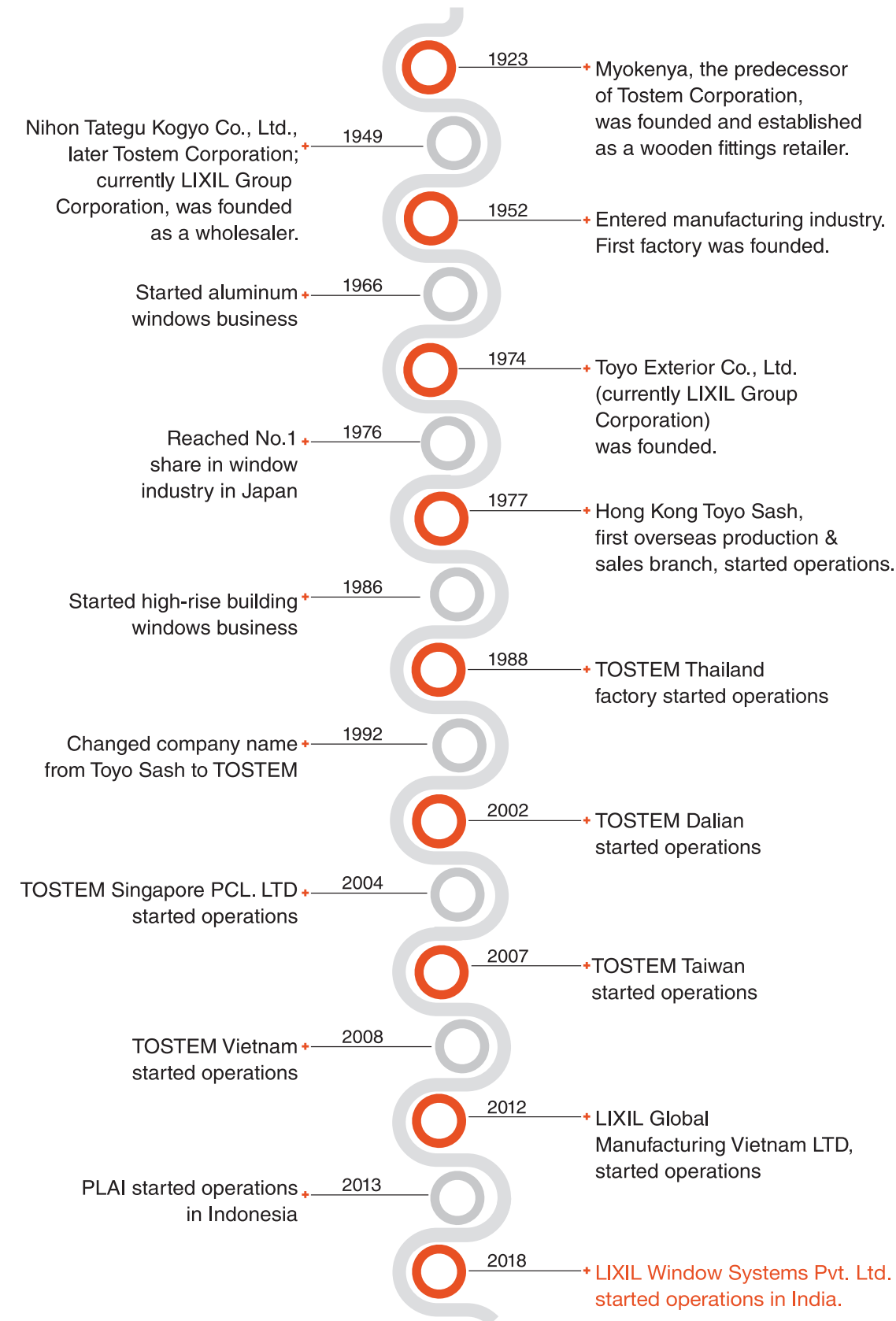

ABOUT TOSTEM

The global leader in pre-engineered window systems

A better home is made up of surprisingly simple things – doors and windows that connect you with the world outside; interiors and exteriors that bring spaces to life.

Recognized as the industry leader, TOSTEM manufactures a comprehensive range of Window & Door solutions. With over 50 years of experience in developing innovative products that not only anticipate the needs of our society tomorrow but equally meet the current needs of clients and consumers in different countries and climates.

Leader in pre-engineered windows

Last mile quality often takes a back seat in the rush to complete a project. One simple answer to the problem is to manufacture the entire window at the factory and only assemble it onsite. This ensures that installation time is compressed and last mile quality is also achieved. It is a well-thought-out Japanese innovation to suit the requirements of housing projects in countries like India.

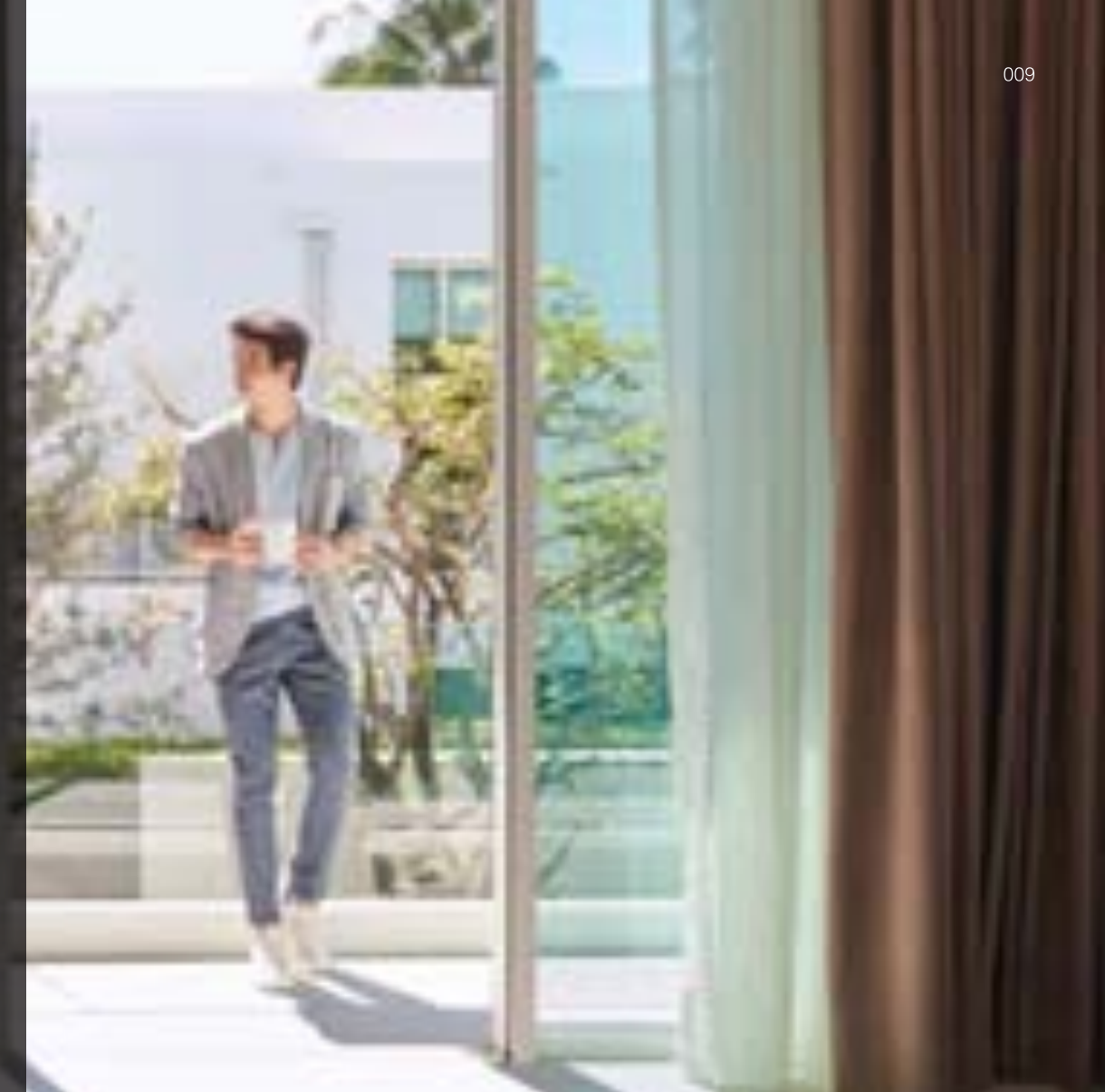

TOSTEM, Thailand - One of the largest window factories in the world!

The facility in Bangkok, Thailand was set up in 1987 and it is dedicated to supplying pre-engineered windows to Japan & other Asian countries. It has an extrusion capacity of 7,000 MT per month, an employee strength of approx. 7,500 and covered area of 591,332 Sq.M. The production capacity is approx. 50,000 windows per day in different SKUs. The larger share is anodized finish, which is highly preferred by customers. The hardware production is in-house and the supply chain is reliably backed by extreme testing.

Ingot to a fabricated window!

Tostem, Thailand is an integrated facility dedicated to the manufacturing of aluminum windows. Starting from the designing of new products, the casting of alloy, extrusion, surface treatment, coating & fabrication - is carried out in-house. A second manufacturing complex with similar capabilities is at Vietnam.

Life cycle testing at accredited test lab!

Quality consistency is achieved by having end-to-end control over the entire manufacturing process. The facility in Thailand has a state-of-the-art testing facility for wind pressure, air tightness, water tightness, material composition & strength, sound isolation, thermal insulation, light & UV resistance & anodizing life test, against both JIS & ASTM Standards. Rollers are tested for 200,000 operations which is many times more than the lifetime use of the product. Detailed inspections are carried out during the design & testing stages to ensure only designs that pass strict quality control tests are made into products for delivery to customers.

TOSTEM PRE-ENGINEERED SYSTEM



All TOSTEM products are designed, manufactured, and assembled under an integrated production process with strict TOSTEM quality control. Extrusion dies, aluminum billet, extrusion poles, coating, pre-engineered, and hardware assembly processes are all done in TOSTEM's factory in Thailand.

The greatest benefit of TOSTEM's pre-engineered system is the ability to build windows with consistent quality. The same window can be built multiple times with a single screwdriver while maintaining consistency in the quality.



In the traditional method - manufacturing, fabrication, and assembly are done partly at the factory and partly onsite. The entire process is slow and quality is very much dependent on the worker's skills at the installation stage. On the other hand, TOSTEM follows a process similar to pre-engineered buildings, where the entire window fabrication is done at the factory and only the glazing and assembly are done onsite in a quick burst of speed. To explain further:

- The manufacturing process is mass production oriented.
- Manufacturing accuracy ensures that there is no mismatch during installation.
- Hardware is fixed at the factory; site work is very minimal.
- The entire window is packed in 2 separate boxes for sash and frame.
- Supplies are made from any of the TOSTEM factories in Bangkok, Vietnam, or Shanghai.



Design performance & actual performance is the same!

Since the entire window is manufactured at the factory, there is no deviation from design performance. The test results can be observed on windows installed onsite.



Control till end stage, site work becomes low skill!

Work at the site usually poses more problems, due to workers skill levels and difficulty in exercising process control. The better solution followed by TOSTEM is to:

- Reduce work content onsite.
- Simplify work so that it can be done by less skilled workers (TOSTEM assembly requires only one tool – a screwdriver).
- Use visual instructions so that training requirements are reduced.



No fabricator dependence!

TOSTEM is a window manufacturer and not merely a fabricator or a system supplier. The entire accountability for timely supplies and quality of the product is with TOSTEM. TOSTEM works with trained installers who would undertake glazing, assembly, and installation of windows. TOSTEM will always ensure that the project is completed within the time promised.



Customer benefits over current solutions!

- Since the window is entirely manufactured in-house, there will be no shortages or rework at the site which can delay site progress.
- Quality is always consistent.
- Perfectly suited to meet high volume requirements of very large projects.



**WINDOW
IN A BOX!**



WHY TOSTEM CAN BE TRUSTED!



Ingot to a fabricated window!

TOSTEM, Thailand is an integrated complex dedicated to the manufacture of Aluminum windows. Design of new products, casting of Alloy, Extrusion, Surface treatment, Coating, and Fabrication is all carried out in-house. A second manufacturing complex with similar capabilities is in Vietnam. Window fabrication units are dispersed across many countries. Quality consistency is achieved by having end-to-end control over the entire manufacturing process.



TOSTEM, Thailand - is one of the largest window factories in the world!

The facility in Bangkok, Thailand was set up in 1987 and is dedicated to supplying Pre-engineered Windows to Japan and other Asian countries. The TOSTEM factory has an Extrusion Capacity of 7,000 MT per month, an employee strength of approx. 7,500 and covered area of 591,332 Sq.M. The product range is very extensive and meets the special requirements of different countries.



Unmatched production capacity!

The production capacity is approx. 50,000 windows per day in different SKUs. The larger share is anodized finish, which is highly preferred by customers. The hardware sourcing is in-house and the supply chain is very reliable.



Quality assurance!

TOSTEM is committed to developing the best products to meet customers' requirements. Detailed inspections are carried out during design and testing stages to assess criteria such as basic performance, durability, weather resistance, and such. Only designs that pass strict quality control tests are made into products for delivery to customers.

HOW TOSTEM BEST MEETS DEVELOPER REQUIREMENTS!



Customer preference for system aluminum windows!

System Windows are becoming highly popular in India due to longer life, greater reliability, and quality assurance. Aluminum is also the dominant material for residential windows in neighboring countries like Singapore, Thailand, Dubai, and the Middle East where the climatic conditions are similar. In these markets, aluminum is seen as a premium window material.



Contemporary designs & slim frames!

By its very nature, metal windows are both slim and strong. It is much easier to fix and operate hardware (metal to metal). Aluminum windows commonly do not require additional steel reinforcing, which is compulsory with other materials. The reinforcing can only be inserted in the middle section leaving the corners very weak. Recent developments in 'Aluminum Minimal Frames' distributes in wind-load across the whole length of the frame. The frame in 'TOSTEM - GRANTS' can also be flushed, to produce an attractive visage of glass. This system is very well suited for high rise buildings and offers a versatile range of design options.



Cost-effective, Japanese products!

TOSTEM products are lean in design and lean in cost. This benefit comes from the excellence of design, high volume manufacturing, and cost control from ingot to fabricated window.

Japanese products like cars have won the confidence of customers in India for their very high reliability, finish, and performance. With TOSTEM, customers will enjoy similar benefits and will appreciate owning a Japanese product.



Brand assurance & brand service!

LIXIL is a large conglomerate with brands like GROHE, American Standard, and INAX in its portfolio. All products have a reputation for the highest quality of service. Continuity and peace of mind are assured with LIXIL.



Unique & easy installation process!

The Pre-engineered window is supplied with 'bottom plates' which are fixed in plumb on the window jamb using spacers, over which the full window is snap fitted. The window is fixed on 3 sides using anchor fasteners and airgaps are closed with silicon on the outside & acrylic inside. The process is fast & easy. No other work is required at site. There is a huge reduction in time required for installation since only the bottom plates is levelled using a spirit leveled and the use of a water line is avoided. Also, less manpower is required since only the bottom plate is to be levelled and not the entire window. Assembly and installation can be done with minimum training. The process can easily be learned. A developer can also use own team for installation.



Low maintenance!

All surfaces and functional parts are designed to perform in a tropical climate. A call center is available in case any service is required by the customer



Come & visit!

Many customers visit the manufacturing facility and the LIXIL Crystal Product Display Center in Bangkok to get a closer feel of TOSTEM products and their manufacturing capabilities.

JAPANESE ENGINEERING & TOSTEM QUALITY!



Traditional batch vs. TOSTEM mass manufacturing!

The traditional method of window manufacturing follows a batch process. General purpose machines are used and chances of mistakes are higher as the process is more man-dependent. Production speeds are also quite low.

The TOSTEM method of manufacturing uses dedicated machines (punch & die set) for every operation. Process control is better and output rates are much higher. It is also easier to exercise quality control as there is a dedicated cell for each window design.



High-precision process!

The punch system of manufacturing followed by TOSTEM is very accurate. Anodizing finish is preferred as it has a uniform thickness of 20 microns. Powder coating is also used, but is more difficult in production, as thickness usually varies between 60-120 microns.

Since manufacturing tolerances are so close - manufacturing accuracy and flatness are also very high, which makes for great ease during glazing and assembly.



Life cycle testing an accredited test lab!

The test lab in Japan is accredited by the Japanese Government. The factory in Thailand has the largest testing facility for wind pressure, air tightness, water tightness, material composition, sound isolation, thermal insulation, light & UV resistance, profile, and anodizing life test against both JIS and ASTM Standards. Rollers are tested for 200,000 operations which is many times more than the lifetime usage of a product.



Ease of operation!

Windows are intended to be opened and closed many times in a day. A key aspect of the design is that effort should be minimal so that even a child can safely open the window. For instance, the effort required to open or close a 2-tract / 4-panel WE Plus Door of 4200 mm width and 2400 mm height with single glass is under 50 N (5 Kgs). The effort is so less that it does not require any mechanical assistance or automation.



Ease of storage & transportation!

The sash and frame are packed in separate boxes. Gaskets are supplied in roll form. The entire bundle is very compact which reduces transportation costs and transit damages. The space required for storage at the site is much less which reduces the chances of theft. Lead and lift requirements are much simplified.



Sustainable materials & fire safety

Aluminum is 100% recyclable and has a higher resale value as compared to other window materials. It is also environment friendly, fire safe and does not release toxic fumes in event of a fire. The life of aluminum windows is much longer.

BENEFITS OF TOSTEM DESIGN!



50 Years' Performance History in Cyclonic Weather at Japan!

TOSTEM is one of the first, large scale manufacturer of aluminum windows in the world. Since the climate at Japan is both cold and cyclonic - highest priority has been given to make windows safe against air and water ingress. Similar to India, the dominant style in Japan is Sliding Windows, which is different from Europe where Casement Tilt & Turn is more popular.



Greater strength, stronger corners, does not bend or crack!

The TOSTEM window is very unique as the section thickness is higher in transverse direction to sustain higher wind load. Also, the thickness is higher at points of screw fixing. The aluminum alloy used is 6063 with T5 tempering which has more strength. The corner is joined at 90° and does not require cleats, which are less strong. The TOSTEM window is stronger and has a longer performance life as compared to other window materials.



Better air & water sealing!

Japanese windows are designed for far better performance against air and water which is very important for comfortable living.

This is achieved by:

- Rubber gaskets are used instead of wool-pile. This provides better sealing against dust, noise and water.
- Gaskets help in smooth operation of window and have a longer life.
- Precision nano-tech gaskets are used at frame corner joints to stop water ingress. It is not necessary to fill joints with silicon which is a common practice with traditional windows.
- Water entry is stopped through use of one-way drainage valve. Also the frame is designed to create a water-head between inside & outside. Using a common rule of thumb, wind pressure up to 10 times of water head can be sustained without entry of water inside.



Special protective coating, higher life & luster!

With the patented TEXGUARD system, the colors of TOSTEM products will last at least 40 years. TEXGUARD is an additional clear synthetic resin paint deposited over the anodized surface which alters the molecular structure of the surface paint and protects the surface against light, heat and water. High scratch resistance of 4H and low accumulation of natural dust makes it easy to clean windows with less effort and retain a new-like look for a long time.



Greater safety with crescent lock

Crescent lock is more sturdy and far safer as compared to a push lock. It can only be locked in one position and it is easy for user to see if the lock is in place. A secondary lock stops crescent lock from inadvertently getting opened.



TOSTEM TOTAL HOUSING SOLUTION

TOSTEM engages in product development, manufacturing, and marketing of a diverse range of home products, such as window sashes, entrance doors, and exterior products. Our product portfolio allows us to provide complete "Lifestyle Solutions" that are flexible, integrated, and coordinated to consumer needs, delivering everyday satisfaction.

WINDOWS & DOORS

Let our aluminum windows and doors frame your world. Our windows and doors come in a variety of sturdy frames to offer you effortless maintenance, years of satisfied use, and of course, a great view.

ENTRANCE DOOR

Stepping into your home should make you relieved, comfortable, and happy. GIESTA high-quality wood-pattern or metallic finish door, equipped with a user-friendly handle with a high-security lock system gives better convenience to both family and visitors and makes us feel glad to be home.

EXTERIOR

FENCE & GATE is a perfect fencing choice for your residence. Our fence and gate solution will enhance the look, feel and overall value of your property, and provide you with the safety and security that your family needs.

NATURAL WHITE

NATURAL SILVER

SHINE GRAY

AUTUMN BROWN

NATURAL BLACK

COLOR PROCESSING

Maximizing the strength and beauty of Aluminum

TOSTEM's unique TEXGUARD anodized finish gives a high level of protection, alongside showing the beautiful appearance of natural Aluminum. TOSTEM offers a wide range of color variations, which allows you to enjoy its lifelong beauty, adding happiness to your lifestyle.

Benefit of TEXGUARD

- Color retention - TEXGUARD protects the Aluminum against harsh environmental conditions, making the color gloss stay for at least 40 years.
- Increased hardness - Dense coating of TEXGUARD improve hardness and provides scratch resistance for the Aluminum surface.
- Ease of cleaning - Dust and dirt accumulation resistance quality of TEXGUARD makes the task of cleaning the surface less effort.

CERTIFICATION

JIS H4100 (NO. TH9009), JIS H8602 (NO. TH9010)
 TIS 218-2520, TIS 284-2530, AAMA 612,
 ISO 9001: 2015 (NO. TH98/4848), ISO 14001: 2004 (NO. TH60/2399)

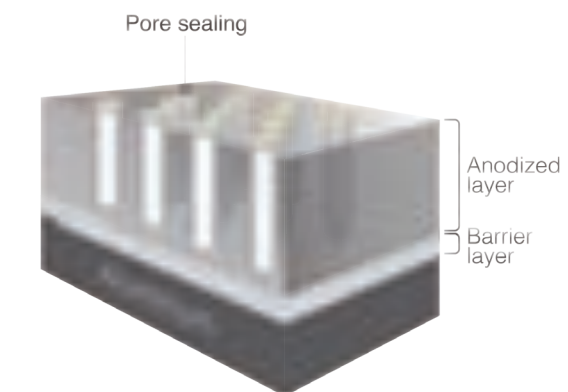

CONVENTIONAL ANODIZE

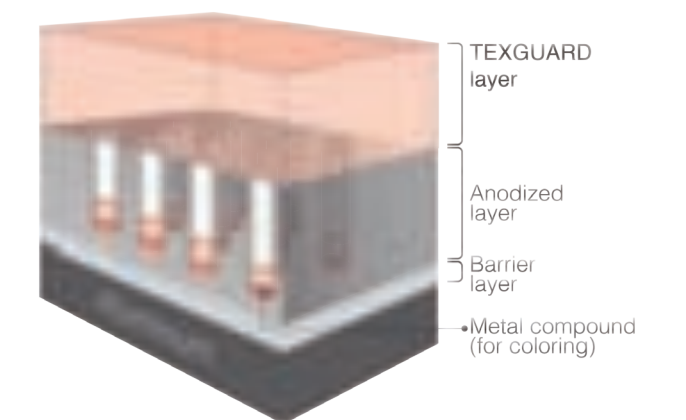

TOSTEM TEXGUARD ANODIZE



reddot winner 2022



GOOD DESIGN AWARD 2021
BEST 100



**DESIGN
AWARD
2022**

L-FIT DESIGN

L-Fit is a handle design that "Fits" in with "Living Life." This standardized design for the handles of windows and entrance doors creates a sense of uniformity and comfort in living space.

QUALITY ASSURANCE

Quality and standards are the core of TOSTEM products.

TOSTEM products are well-known for their rigorous standard control by Quality Assurance and Quality Control Systems, to ensure only products that pass strict quality-control tests are allowed to be offered to customers. TOSTEM has state-of-the-art testing facilities for wind pressure, air tightness, water tightness, material composition and strength, sound isolation, thermal insulation, light and UV resistance, and anodizing life test, against both JIS and ASTM standards.



WATER PENETRATION

TOSTEM products are tested on a full-size window as per the most stringent global standards like JIS and ASTM, which ensures the watertight performance of the window.



SOUND INSULATION

At TOSTEM, windows are tested for the level of sound that can be insulated in a controlled test chamber to ensure excellent sound insulation property of the windows.



WIND-LOAD RESISTANCE

TOSTEM windows are tested for wind-load resistance performance to ensure that the window can resist a level wind load in area height without any loss, cracking, or breakage.



ENVIRONMENTAL TESTING

Every TOSTEM product is tested for its resistance to adverse effects of various climatic conditions such as moisture, dust, sunlight, and pollution to resist rusting and irregular fading under environmental conditions.



MATERIALS TESTING

TOSTEM Products are tested for tensile strength and compression strength to verify the lifetime durability of Aluminium bars and hardware.



DURABILITY

At TOSTEM, we test the window durability in real-life operations on parameters like open-close operation, endurance to impact, and overall product durability, to ensure that the windows last up to 2,00,000 cycles of operations.

WHY PERFORMANCE IS IMPORTANCE TO US?

Wind loading resistance performance

WIND LOADING RESISTANCE PERFORMANCE indicates at what level windows and doors can bear the wind load.

THE PURPOSE is to ensure that selected windows can resist a level of wind load in area and height without any loss, cracking, or breakage.

WIND PRESSURE RESISTANCE
JIS (A4702-2000 and A4706-2000)

| Class | Value corresponding to each class |
|--------------------|-----------------------------------|
| | [Maximum pressure] |
| Higher ↑ S-7 (360) | 3600 Pa |
| S-6 (280) | 2800 Pa |
| S-5 (240) | 2400 Pa |
| S-4 (200) | 2000 Pa |
| S-3 (160) | 1600 Pa |
| S-2 (120) | 1200 Pa |
| S-1 (80) | 800 Pa |



WIND PRESSURE AND VELOCITY

| Wind pressure | Wind velocity | Phenomenon |
|---------------|---------------|---|
| 1800 Pa | 60 m/s | Steel tower may fall down. |
| 1250 Pa | 50 m/s | Wooden houses will collapse. |
| 800 Pa | 40 m/s | Tiles will fly. Antennas will fall off. |
| 450 Pa | 30 m/s | Twigs will snap off. Cannot stand on your own. |
| 200 Pa | 20 m/s | Signboard will fall over. Cannot walk towards the wind. |
| 50 Pa | 10 m/s | Cannot use umbrella. Hard to walk toward the wind. |

AIR TIGHTNESS
JIS (A4702-2000 and A4706-2000)

| Class | Value to corresponding to each class |
|------------------|---|
| | [Air leak] ∠P=10Pa |
| Higher ↑ A-4 (2) | 2m ³ / m ² / hour |
| A-3 (8) | 8m ³ / m ² / hour |
| A-2 (30) | 30m ³ / m ² / hour |
| A-1 (120) | 120m ³ / m ² / hour |

AIR TIGHTNESS PERFORMANCE

AIR TIGHTNESS PERFORMANCE indicates how much air can pass through gaps between frame and panel of windows and doors.

THE PURPOSE is to evaluate the level of air coming into a room. This performance is also related to dust prevention, sound insulation and thermal insulation.



WATER TIGHTNESS PERFORMANCE

WATER TIGHTNESS PERFORMANCE indicates the rate at which a window can prevent the infiltration of rainwater into a room.

THE PURPOSE is to help select a watertight performance that can prevent interior damage from water intrusion into a room.

WATER TIGHTNESS JIS (A4702-2000 and A4706-2000)

| Class | Value corresponding to each class |
|-------------------|-----------------------------------|
| | [Pressure difference] |
| Higher ↑ W-5 (50) | 500 Pa |
| W-4 (35) | 350 Pa |
| W-3 (25) | 250 Pa |
| W-2 (15) | 150 Pa |
| W-1 (10) | 100 Pa |



SOUND INSULATION PERFORMANCE

SOUND INSULATION PERFORMANCE indicates a level of sound blocked out from outside to inside.

THE PURPOSE is to measure the level of sound that can be insulated by a window. Each project may have different sound insulation level requirements.



SOUND INSULATION PERFORMANCE
JIS (A4706 and A4702)

| Class | Sound transmission class |
|--------------|--------------------------|
| Higher ↑ T-4 | 40 dB |
| T-3 | 35 dB |
| T-2 | 30 dB |
| T-1 | 25 dB |

SOUND PERCEPTION
Perception towards noises varies among individuals. However, it is said that when the noise level is lowered by 10 dB (A), people feel that the noise level has halved.

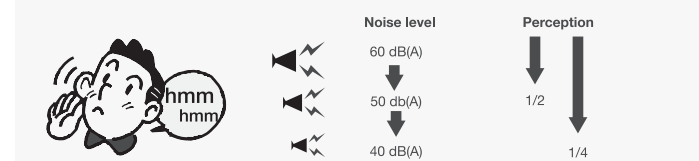

| Noise level dB(A) | Surrounding noise | Same noise during mid day | Impact on Hearing |
|-------------------|--|---|----------------------------|
| 110 | Klaxon (1m distance) / Sound from press machine | | Hearing dysfunction |
| 100 | Underneath the elevated railway tracks when trains are running | | |
| 90 | In trains / At the bowling alley | Beside the railway tracks/ Motorway | Extremely Noisy |
| 80 | Intersection of main avenue / Bus traffic level | Residential area in the city/ Motorway / Street of office building | |
| 70 | On the street / Taxi traffic level | Residential area in the city/ Motorway / Residential area in suburban district / Street of office buildings | Noisy |
| 60 | Inside of department stores/ Normal conversation | Residential area in the city | |
| 50 | Quiet offices | Residential area in suburban district | Ideal level for daily life |
| 40 | Quiet parks | Residential area in suburban district | |
| 30 | Suburban area around midnight | | Quiet |
| 20 | Whisper | | |



TOSTEM AIRFLOW SYSTEM

TOSTEM AIRFLOW System includes GIESTA AIRFLOW: a steel wooden pattern door with integrated ventilation, AIRFLOW Door: a ventilation door with sliding window for multiple ventilation levels, and AIRFLOW SLOT: a slot for ventilation with flap in a top-notch design compatible with various TOSTEM window designs seamlessly.

1
GIESTA
AIRFLOW



CLOSE



OPEN

2
AIRFLOW SLOT
(available for WE 70)



CLOSE



OPEN

3
AIRFLOW
DOOR



CLOSE



OPEN

TOSTEM WINDOW AND DOOR SERIES

| | | FRAME DEPTH, HEIGHT OF SILL | DESIGN | PERFORMANCE | GLASS APPLICATION |
|---------------|--|---|--|---|---|
| GRANTS SERIES |  | GRANTS Frame depth : 101.6 / 120 / 178 mm Height of sill : 50 mm | TRADITIONAL MINIMAL  | LOW-RISE HIGH-RISE  | 5 MM (SG) ~15MM (LG) ~32MM (IGU)  |
| ATIS SERIES |  | ATIS PLUS Frame depth : 88 / 131.5 mm Height of sill : 55 mm | TRADITIONAL MINIMAL  | LOW-RISE HIGH-RISE  | 5 MM (SG) ~15MM (LG) ~32MM (IGU)  |
| | | ATIS Frame depth : 88 / 131.5 mm Height of sill : 55 mm | TRADITIONAL MINIMAL  | LOW-RISE HIGH-RISE  | 5 MM (SG) ~15MM (LG) ~32MM (IGU)  |
| WE SERIES |  | WE PLUS Frame depth : 72 / 104 mm Height of sill : 35 mm / 50 mm | TRADITIONAL MINIMAL  | LOW-RISE HIGH-RISE  | 5 MM (SG) ~15MM (LG) ~32MM (IGU)  |
| | | WE 70 Frame depth : 72 / 104 mm Height of sill : 35 mm | TRADITIONAL MINIMAL  | LOW-RISE HIGH-RISE  | 5 MM (SG) ~15MM (LG) ~32MM (IGU)  |



ATIS PLUS WINDOWS



Sliding Window
(2 panels on 2 tracks)
P. 56



Sliding Window
(4 panels on 2 tracks)
P. 56



Awning Window
P. 56



Casement Window
P. 56



Fixed Window
P. 56



Fixed Unit
Variation
P. 57

Product detail

ATIS PLUS DOORS



Sliding Door
(2 panels on 2 tracks)
P. 57



Sliding Door
(4 panels on 2 tracks)
P. 57



Out-Swing Door
(Single)
P. 57

Product detail

GRANTS Series (Windows)



Sliding Window
(2 panels on 2 tracks)
P. 38



Sliding Window
(4 panels on 2 tracks)
P. 38



Sliding Window
(3 panels on 2 tracks) SFS
P. 38



Fixed Window
P. 39



Awning Window
P. 38



Casement Window
P. 38-39



Corner Fixed Window
P. 39



Mixed Window
P. 40

Product detail

GRANTS Series (Doors)



Sliding Door
(2 panels on 2 tracks)
P. 39



Sliding Door
(4 panels on 2 tracks)
P. 39



Sliding Door
(3 panels on 2 tracks) SFS
P. 39



Sliding Door
(3 panels on 3 tracks)
P. 40



Sliding Door
(6 panels on 3 tracks)
P. 40



Out-Swing Door
(Single)
P. 40



Insect Screen
for Awning & Casement
P. 40

Product detail

ATIS WINDOWS



Sliding Window
(2 panels on 2 tracks)
P. 58



Sliding Window
(4 panels on 2 tracks)
P. 58



Awning Window
(Single Lock)
P. 58



Awning Operator
Window
P. 58



Awning Slit
Window
P. 58



Casement Window
(Single Lock)
P. 59

Product detail



Casement Operator
Window
P. 59



Fixed Window
P. 59



Corner Fixed
Window
P. 59



Fix Unit
Variation
P. 59



Tilt & Slide
P. 60

ATIS DOORS



WE PLUS Series (Windows)



WE PLUS Series (Doors)



Out-Swing Door (Single)

WE 70 Series (Windows)

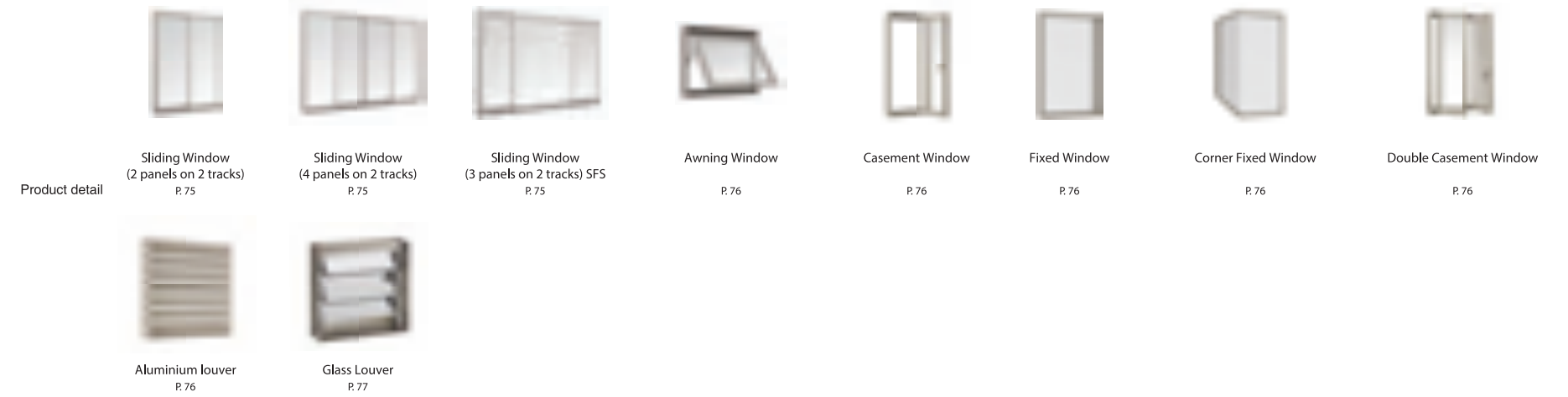

WE 70 Series (Doors)

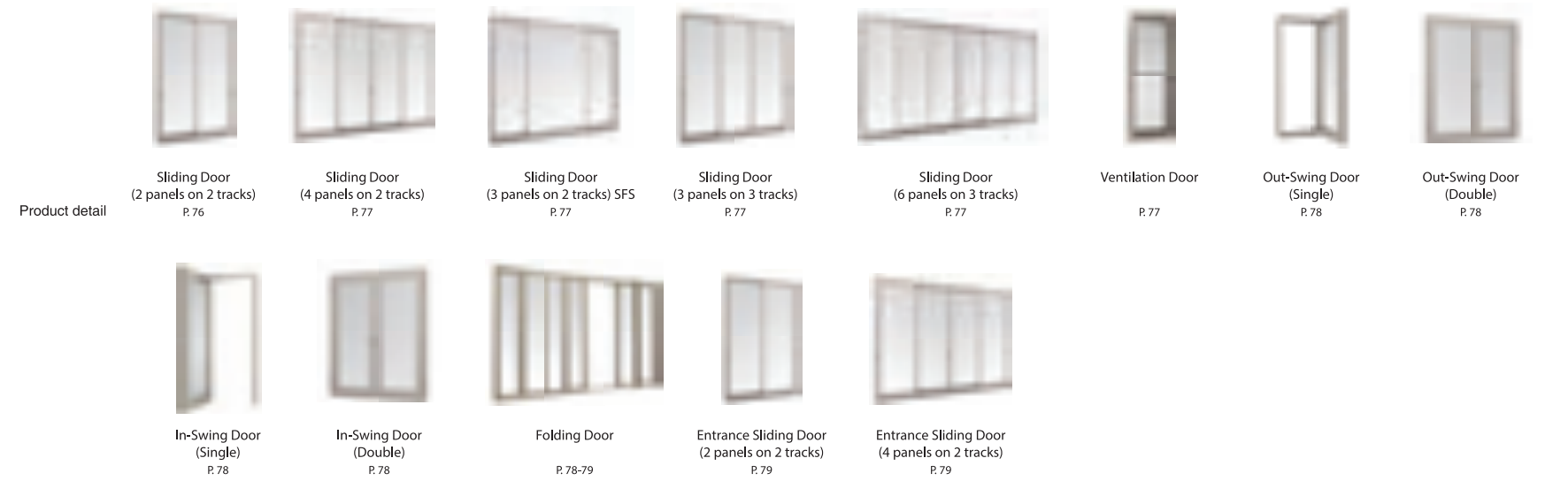

Interior Series





GRANTS SERIES

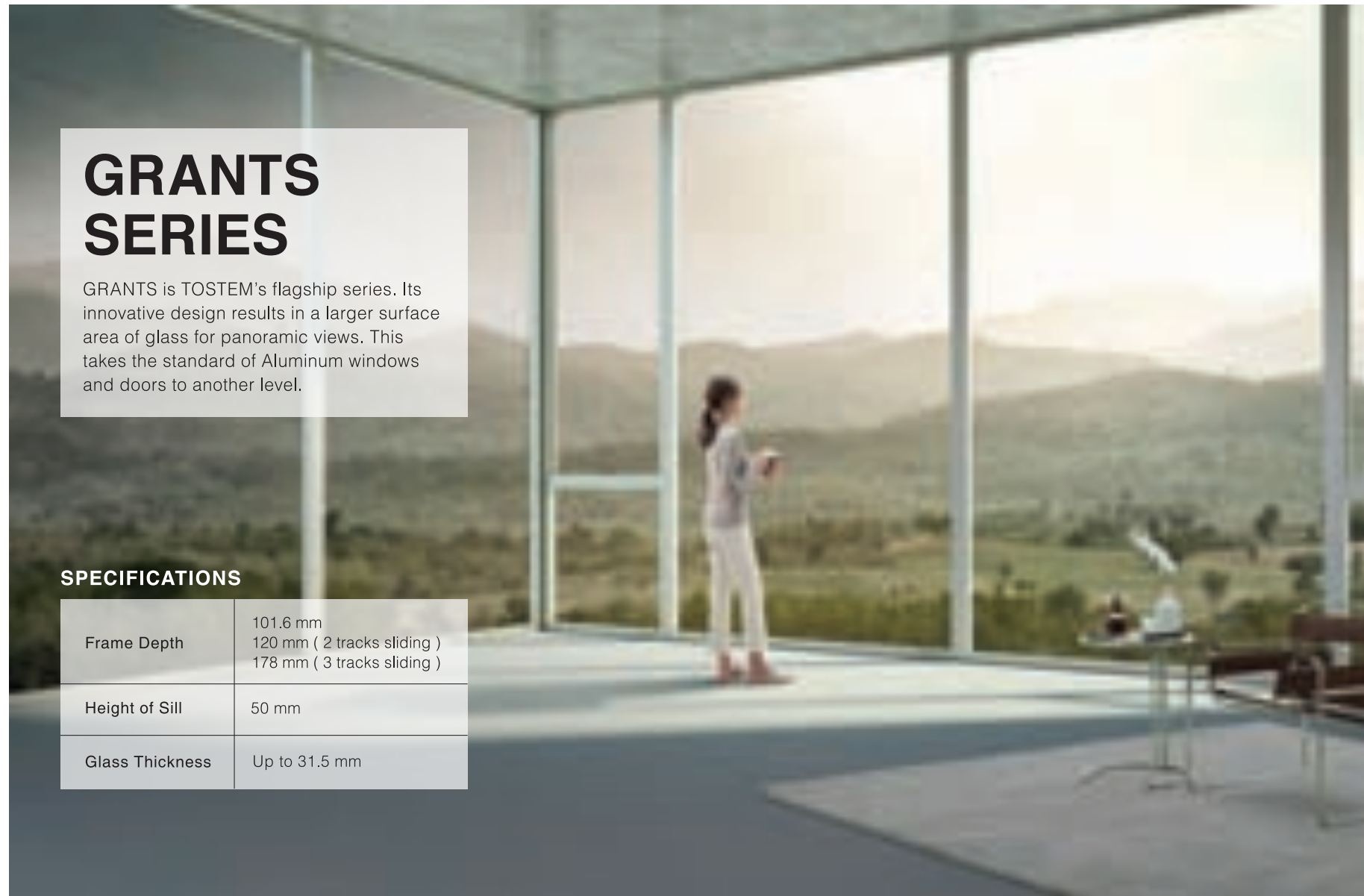

GRANTS SERIES

GRANTS is TOSTEM's flagship series. Its innovative design results in a larger surface area of glass for panoramic views. This takes the standard of Aluminum windows and doors to another level.

SPECIFICATIONS

| | |
|-----------------|--|
| Frame Depth | 101.6 mm 120 mm (2 tracks sliding) 178 mm (3 tracks sliding) |
| Height of Sill | 50 mm |
| Glass Thickness | Up to 31.5 mm |

COLOR



PERFORMANCES

| | | | |
|---|--|---|--|
| <p>WIND PRESSURE</p> <p>2000 Pa (ASTM E330)</p> | <p>WATER TIGHTNESS</p> <p>300 Pa (ASTM E331)</p> | <p>AIR TIGHTNESS</p> <p>10.7m³ / h·m² (ASTM E283)</p> | <p>NOISE INSULATION*</p> <p>T-1 (25 dB) (JIS A 1416)</p> |
|---|--|---|--|

* Sound performance test has been done in a JIS standard controlled environment. The performance will vary by room condition. Please consult with a sound insulation specialist.

UNIQUE FEATURES

Streamline design (Concealed panel)



Double barrier drainage system



Overlapping meeting stile (4 Panels sliding)

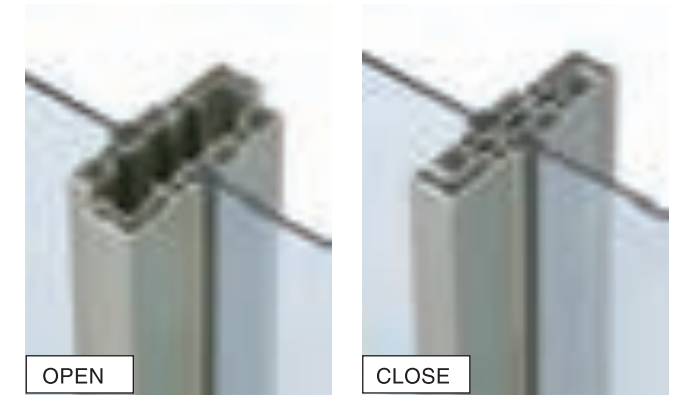

L-FIT DESIGN HANDLES

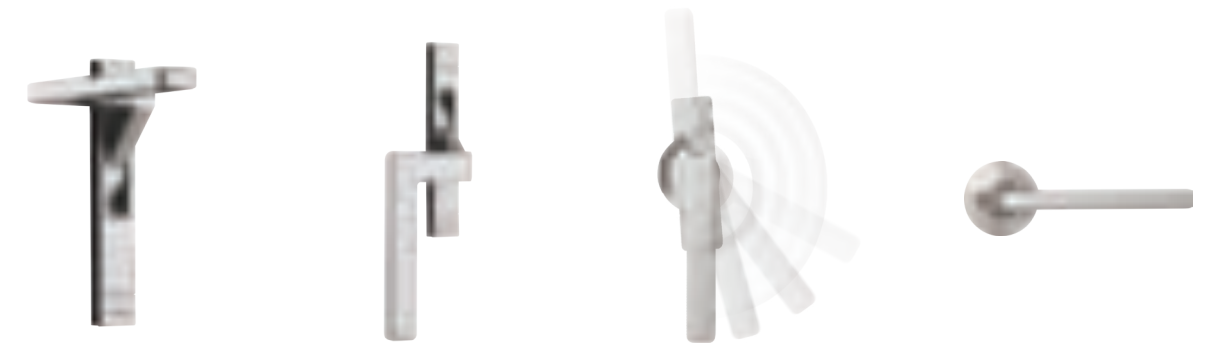

GRANTS SCREEN SYSTEM

FOR AWNING AND CASEMENT WINDOWS

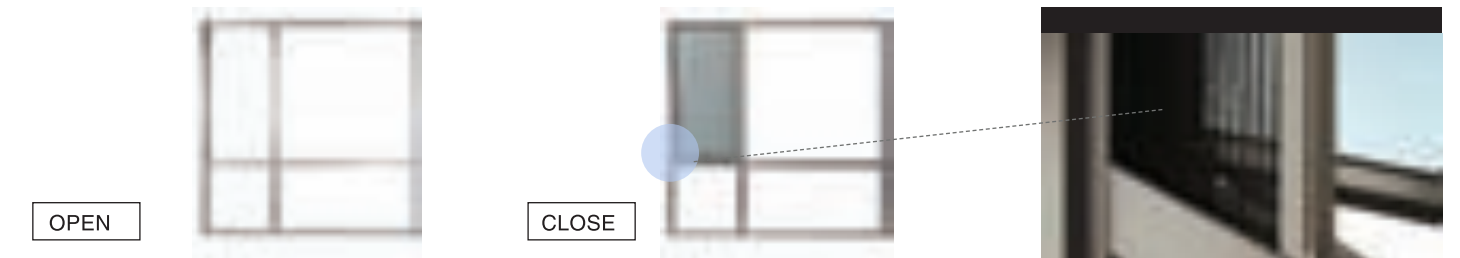

- Fully embedded in the frame.
- Easy to remove for maintenance.

FOR SLIDING AND SWING DOORS

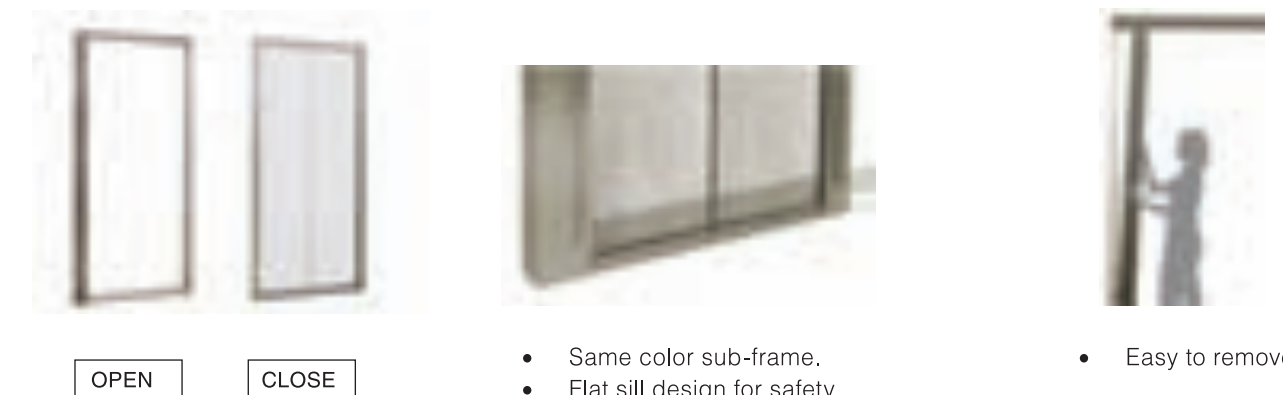

- Same color sub-frame.
- Flat sill design for safety.
- Easy to remove.

GRANTS

WINDOW **DOOR**

OPTION **MIX**

- Available in SG and IG unit

SLIDING WINDOW (2 PANELS ON 2 TRACKS)



- Handle option
- Select panel position from L/R
- Single slide (L/R) available
- Glazing finish
 - 8 - 13.52 mm : Glazing channel
 - Other glass : Sealant

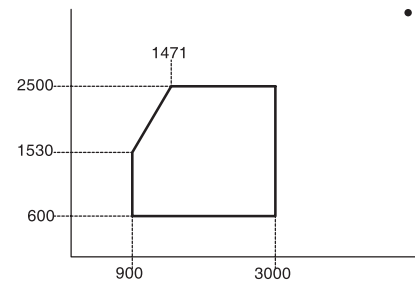

CASEMENT WINDOW (WITH HINGE OR PIVOT)



- Select from L/R
- Pleated insect screen available
- Glazing finish
 - 8 - 13.52 mm : Glazing channel
 - 28 - 31.52 mm : Glazing channel
 - Other glass : Sealant

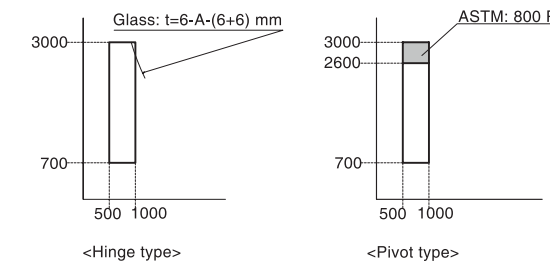

FIXED WINDOW



- For oversize fixed windows, please consult with our technician
- Glazing finish
 - 8 - 13.52 mm : Glazing bead
 - 25 - 31.52 mm : Glazing bead
 - Other glass : Sealant

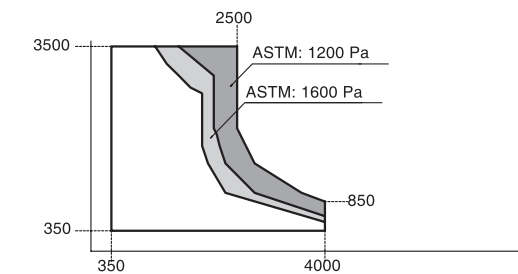

SLIDING WINDOW (3 PANELS ON 2 TRACKS) SFS



- Handle option
- Glazing finish
 - 8 - 13.52 mm : Glazing channel
 - Other glass : Sealant

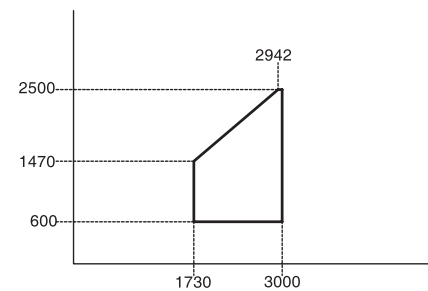

SLIDING WINDOW (4 PANELS ON 2 TRACKS)



- Handle option
- Select from (SSSS, FSSF)
- Glazing finish
 - 8 - 13.52 mm : Glazing channel
 - Other glass : Sealant

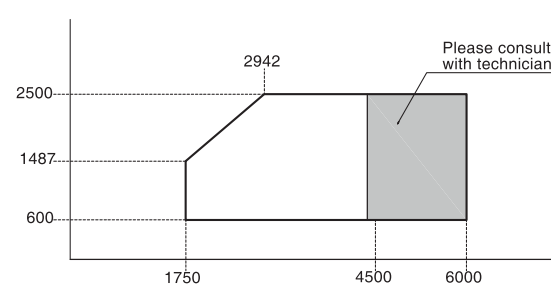

CORNER FIXED WINDOW



- Only available in SG
- Only available with sealant finish
- Both in/outward corner available

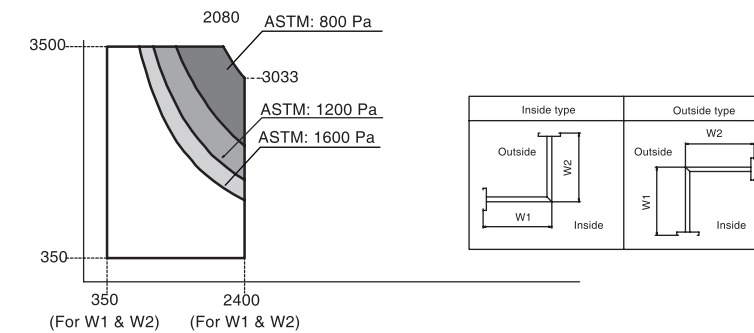

SLIDING DOOR (2 PANELS ON 2 TRACKS)



- Handle option
- Select panel position from L/R
- Single slide (L/R) available
- Glazing finish
 - 8 - 13.52 mm : Glazing channel
 - Other glass : Sealant

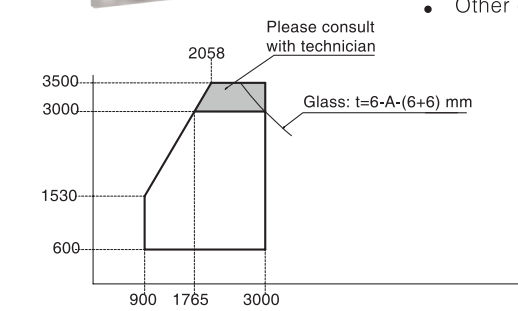

AWNING WINDOW



- In case of IG, please consult with our technician for size and performance
- Pleated insect screen available
- Glazing finish
 - 8 - 13.52 mm : Glazing channel
 - 28 - 31.52 mm : Glazing channel
 - Other glass : Sealant

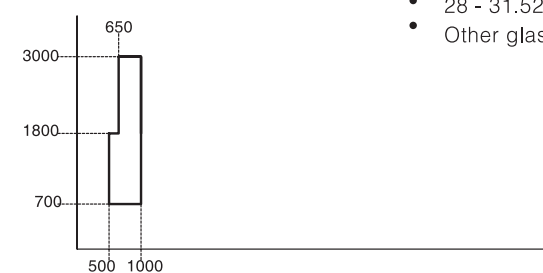

CASEMENT WINDOW (WITH FRICTION STAY)



- In case of glass thickness over 8 mm and IG unit please consult with our technician
- Select from L/R
- Pleated insect screen available
- Glazing finish
 - 8 - 13.52 mm : Glazing channel
 - 28 - 31.52 mm : Glazing channel
 - Other glass : Sealant

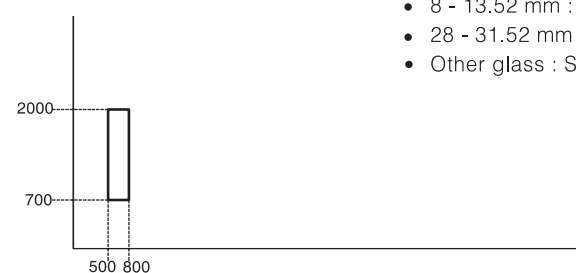

SLIDING DOOR (4 PANELS ON 2 TRACKS)



- Handle option
- Select from (SSSS, FSSF)
- Glazing finish
 - 8 - 13.52 mm : Glazing channel
 - Other glass : Sealant

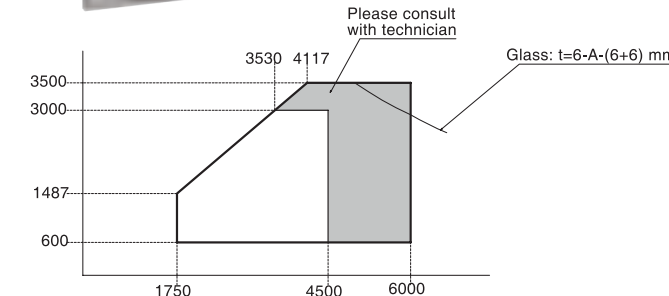

SLIDING DOOR (3 PANELS ON 2 TRACKS) SFS



- Handle option
- Glazing finish
 - 8 - 13.52 mm : Glazing channel
 - Other glass : Sealant

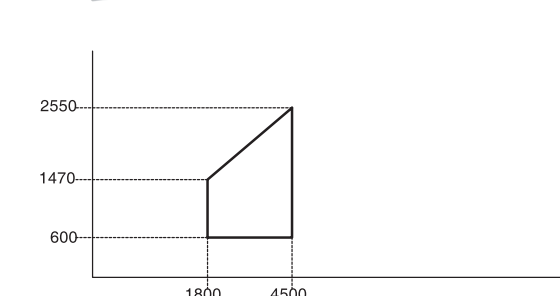

SLIDING DOOR (3 PANELS ON 3 TRACKS)



- Handle option
- Select panel position from L/R
- Select from (SSS, FSS, SSF)
- Glazing finish
 - 8 - 13.52 mm : Glazing channel
 - Other glass : Sealant

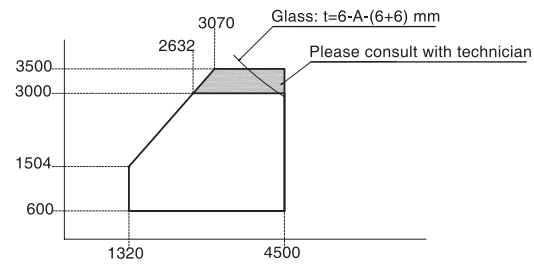

SLIDING DOOR (6 PANELS ON 3 TRACKS)



- Handle option
- Select from (SSSSSS, FSSSSF)
- Glazing finish
 - 8 - 13.52 mm : Glazing channel
 - Other glass : Sealant

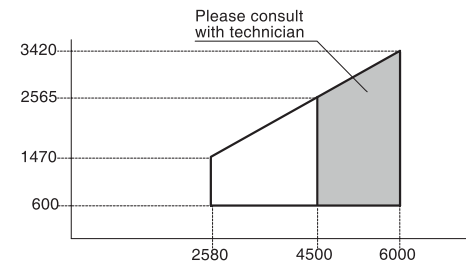

OUT-SWING DOOR (SINGLE)



- Pivot hinge option
- Door closer NOT available
- Select from L/R
- Glazing finish
 - 8 - 13.52 mm : Glazing channel
 - 28 - 31.52 mm : Glazing channel
 - Other glass : Sealant

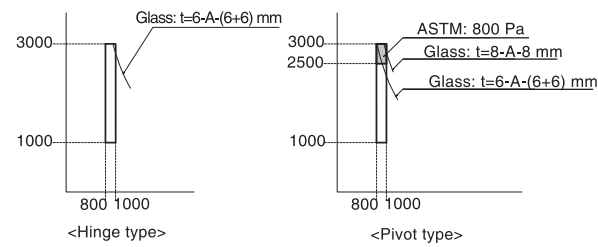

INSECT SCREEN



- This insect screen is for awning and casement window



MIXED & COMBINATION WINDOW

- Mullions are available for various windows and doors, Please consult with our sales representative for selection
- 180° mullion (standard and reinforced)
- 90° mullion (only for outward corner)

UNIT WINDOWS

| Bottom Windows | Top Windows | | | |
|-----------------|---------------|-----------------|------------|---------|
| | Single Awning | Single Casement | Single Fix | Sliding |
| Single Awning | | | • | |
| Single Casement | | | • | |
| Swing Door | | | • | |
| Single Fix | • | • | • | • |
| Double Fix | | | | • |





**GRANTS PROJECT
REFERENCE**

PRIVATE HOUSE, KHON KAEN





ATIS SERIES



ATIS PLUS

ATIS PLUS offers beautiful windows and doors for your high-rise projects, which has passed rigorous tests based on ASTM and TOSTEM in-house toughness standard.

SPECIFICATIONS

| | |
|-----------------|---|
| Frame Depth | 88 mm 131.5 mm (3 tracks sliding) |
| Height of Sill | 55 mm |
| Glass Thickness | 5,6,8 - 15.52,22 mm (26 mm for fixed window) |



ATIS

ATIS is not only esthetically pleasing but has an enormous amount of innovation and technology "build within". All ATIS products follow the same simple design concept: Seamlessly unite the inside of your home with the outside without taking anything away.

SPECIFICATIONS

| | |
|-----------------|---|
| Frame Depth | 88 mm 131.5 mm (3 tracks sliding) |
| Height of Sill | 55 mm |
| Glass Thickness | 5,6,8 - 15.52,22 mm (26 mm for fixed window) |

COLOR

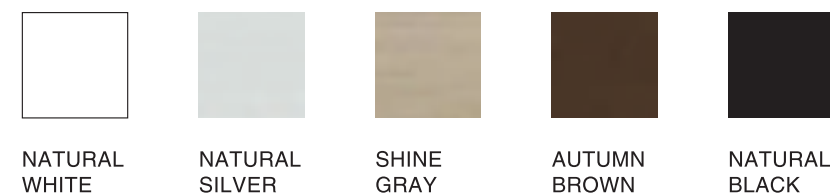

NATURAL WHITE NATURAL SILVER SHINE GRAY AUTUMN BROWN NATURAL BLACK

PERFORMANCES

| | | | |
|---|--|--|---|
|  WIND PRESSURE 2000 PA (ASTM E330) |  WATER TIGHTNESS 300 PA (ASTM E331) |  AIR TIGHTNESS 10m ³ /h·m ² (ASTM E283) |  NOISE INSULATION *1 T-1 (25dB for openable windows)*2 (JIS A 1416) T-2 (30dB for fixed window) |
|---|--|--|---|



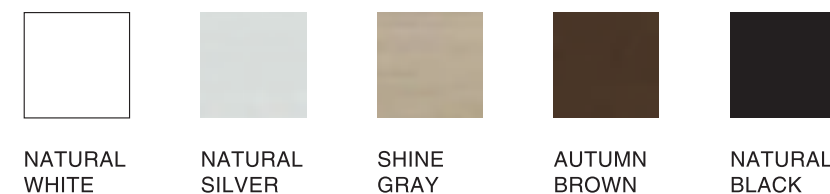

*1: Sound performance test has been done in a JIS standard controlled environment. The performance will vary by room condition. Please consult with a sound insulation specialist.
 *2: Some specific window types and glasses

COLOR



NATURAL WHITE NATURAL SILVER SHINE GRAY AUTUMN BROWN NATURAL BLACK

PERFORMANCES

| | | | |
|--|---|---|---|
|  WIND PRESSURE S-2 (1200 PA) (JIS A 1515) |  WATER TIGHTNESS W-3 (250 PA) (JIS A 1517) |  AIR TIGHTNESS A-4 (2m ³ /h·m ²) (JIS A 1516) |  NOISE INSULATION *1 T-1 (25dB for openable windows)*2 (JIS A 1416) T-2 (30dB for fixed window) |
|--|---|---|---|

*1: Sound performance test has been done in a JIS standard controlled environment. The performance will vary by room condition. Please consult with the sound insulation specialist.
 *2: Some specific window types and glasses



ATIS UNIQUE FEATURES

STREAMLINED DESIGN

Seamless design with beautiful functionality. Smooth lines, surfaces, and operation. Works as beautifully as it looks.

CONCEALED HARDWARE



LOCKS



HINGES



BALANCER

*Only available for ATIS series

SLIM MULLION



40 mm MULLION

L-FIT DESIGN HANDLES



OPERATOR HANDLE

*Only available for ATIS series



CAM-LATCH HANDLE



LEVER HANDLE



CRESCENT LOCK

SMART INSECT SCREEN

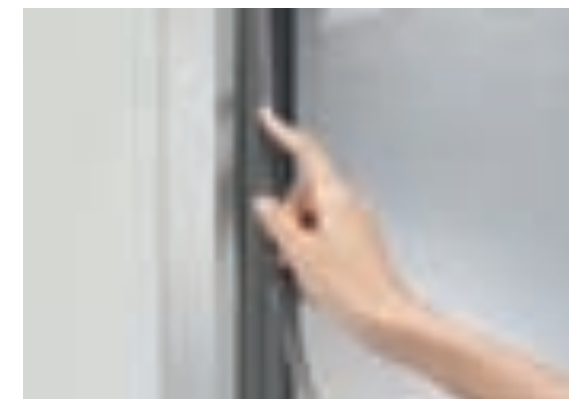

*Only available for ATIS series

INVISIBLE SCREEN



We use a 40% thinner wire than conventional insect screens. So you get a 20% clearer view.



We have shrunk the space for bugs to squeeze through by 20%, so not even the tiniest gnat can get in.

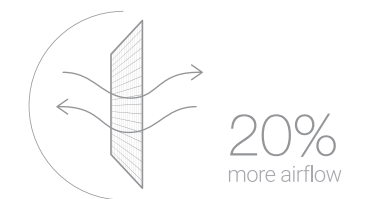

With more AIRFLOW than conventional insect screens, INVISIBLE SHIELD lets more insect-free AIRFLOW through than any others.

AWNING/CASEMENT



L-FIT HANDLE

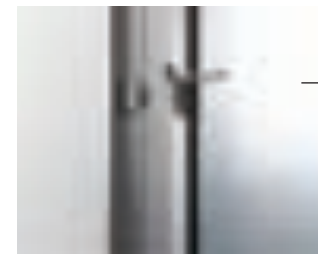

LIMIT ARM FOR SAFETY (OPTION)



CASEMENT WINDOW (WITH CAM-LATCH HANDLE)



CASEMENT WINDOW (WITH OPERATOR HANDLE)

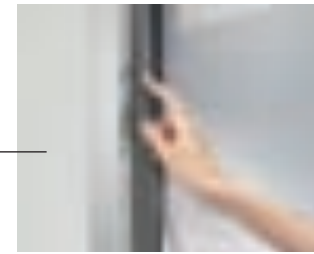

SMART INSECT SCREEN SYSTEM



L-FIT DESIGN HANDLE

SLIT WINDOW WITH CHAIN OPERATOR



Specially designed for rooms where you want to keep outside eyes out but let the breeze in. You can open our slit windows without having to reach up to the window height. We help you make the most out of every living area in your home.



TILT & SLIDE

LOCK DEVICE



LOCKED

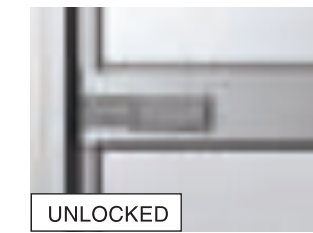

UNLOCKED

SAFETY STOPPER



CONCEALED POWER SUPPORT SYSTEM



SLIDING INSECT SCREEN (OUTSIDE)



CLOSED POSITION



TILTED POSITION



OPENED POSITION



SLIDING WINDOW / DOOR



ALUMINUM PROFILE HANDLE



LIMIT ARM (OPTION)

FLAT ATTACHMENT (OPTION)

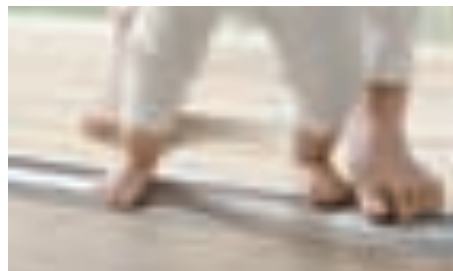

SAFE FOR EVERYONE



DETACHABLE



FOR OUTER RAIL (OUTER PANEL FIXED)



FOR INNER RAIL (INNER PANEL FIXED)

SWING DOOR

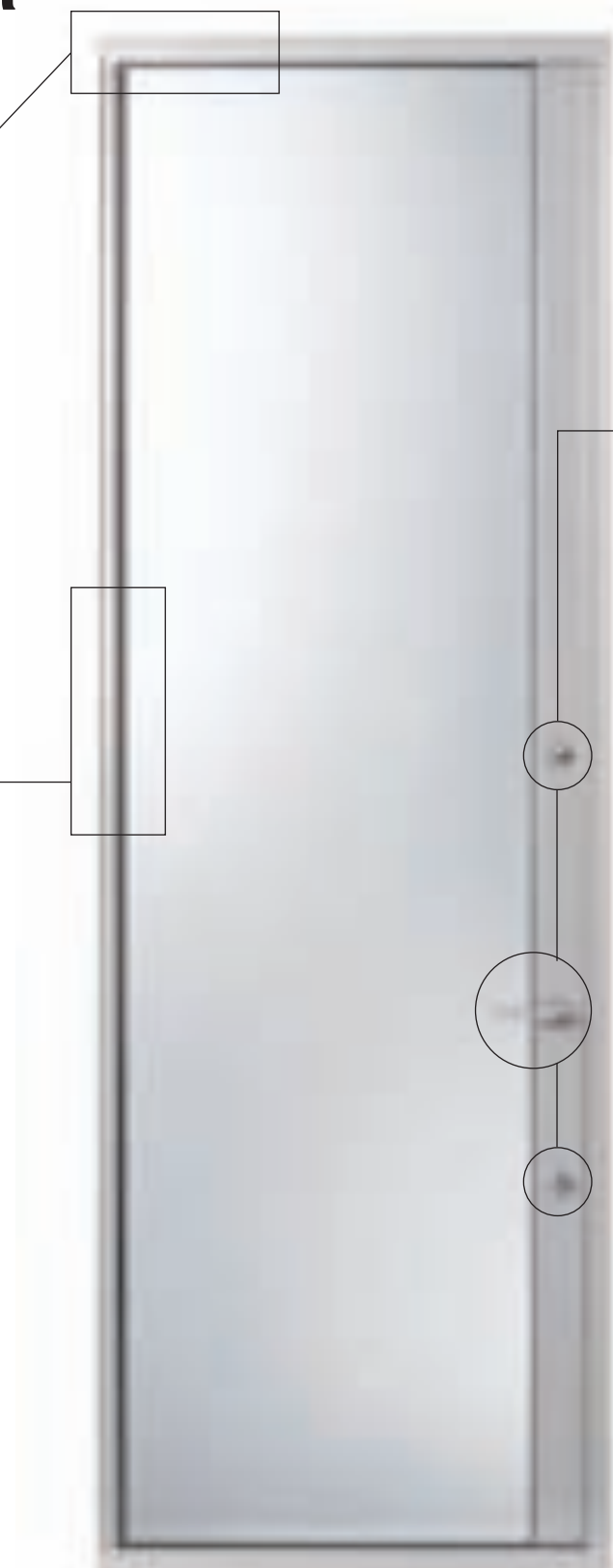

CONCEALED FRICTION ARM



CONCEALED HINGES

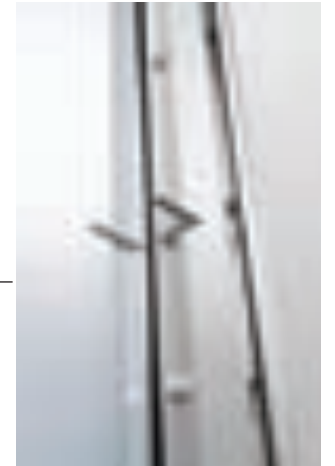

L-FIT DESIGN HANDLE AND LOCK SET

<CONVENTIONAL>



<ATIS>



DOUBLE SWING DOOR WITH MAXIMIZED GLASS AREA (RECOMMENDED FOR LOW-RISE PROJECTS)

ATIS PLUS

- WINDOW** **DOOR**
- OPTION** **MIX**

- Available in SG and IG unit

SLIDING WINDOW (2 PANELS ON 2 TRACKS)

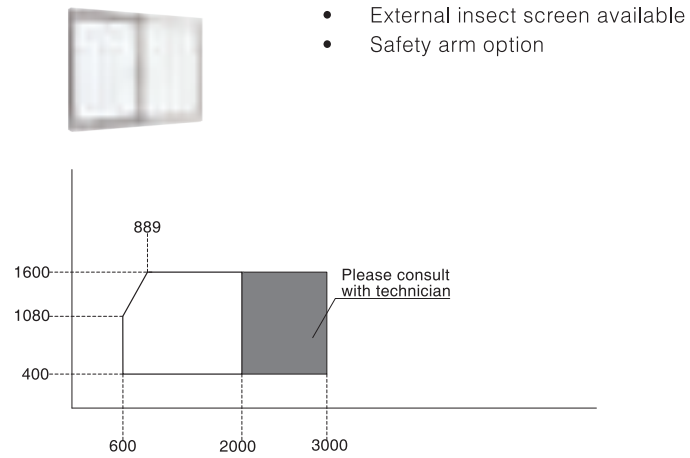

FIX UNIT VARIATION

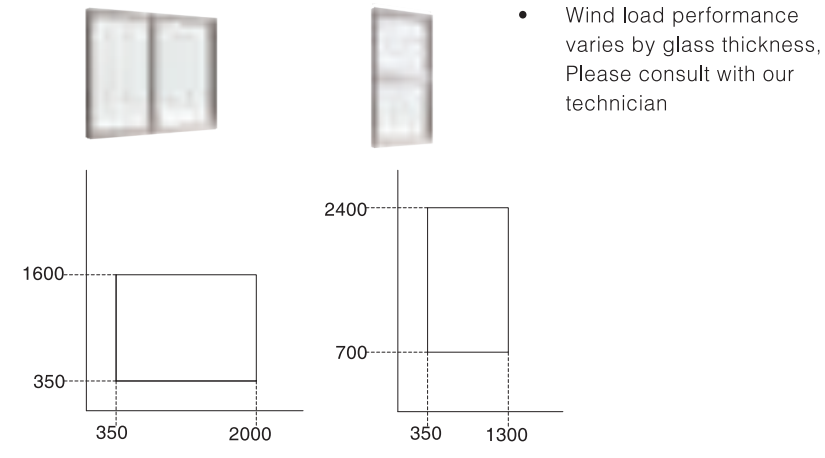

SLIDING DOOR (2 PANELS ON 2 TRACKS)

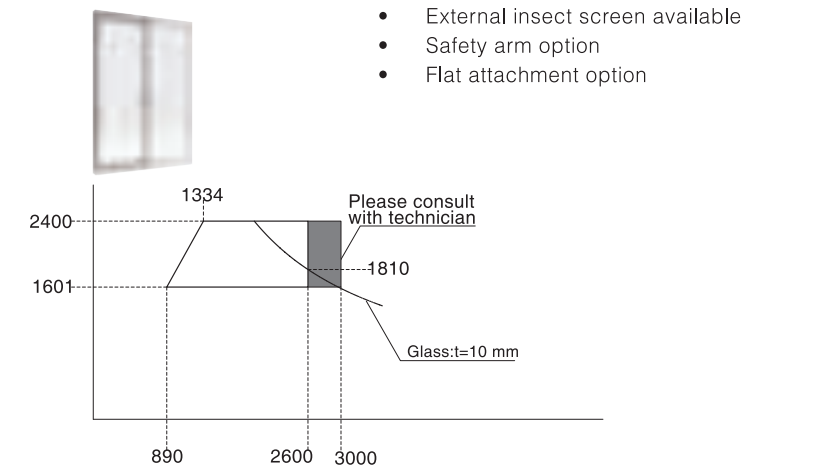

SLIDING WINDOW (4 PANELS ON 2 TRACKS)

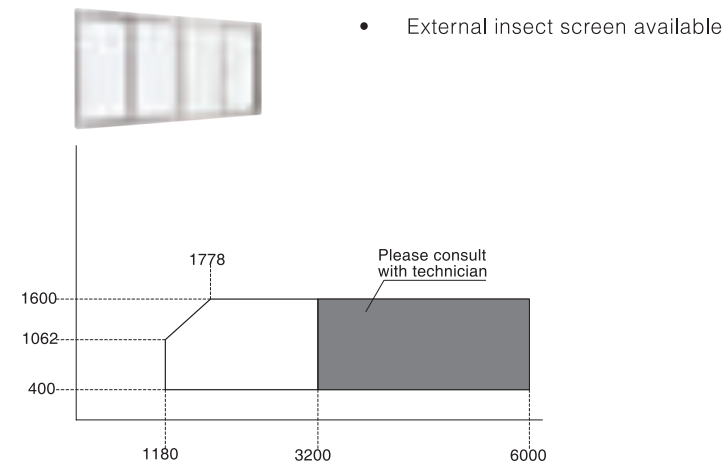

AWNING WINDOW (MULTI LOCK)

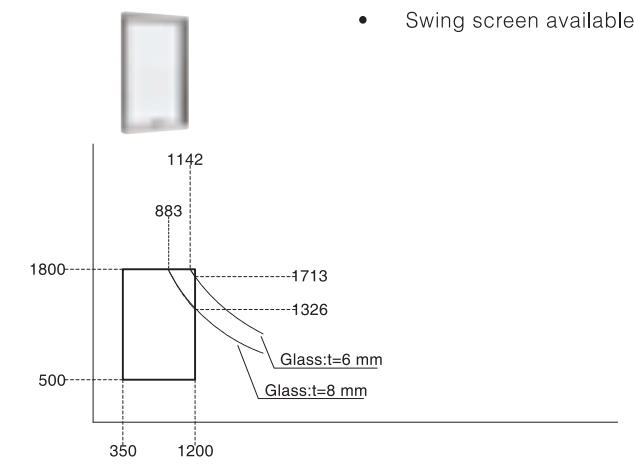

SLIDING DOOR (4 PANELS ON 2 TRACKS)

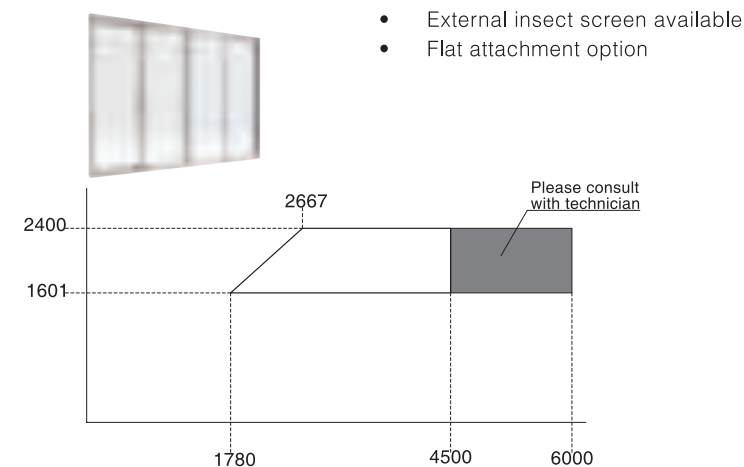

OUT-SWING DOOR (SINGLE)



CASEMENT WINDOW (MULTI LOCK)

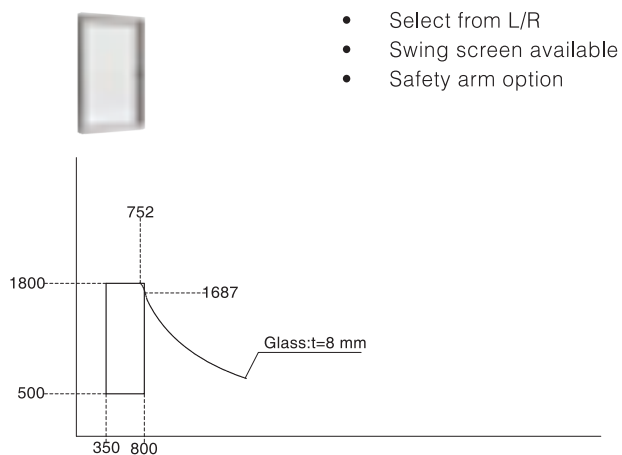

FIXED WINDOW

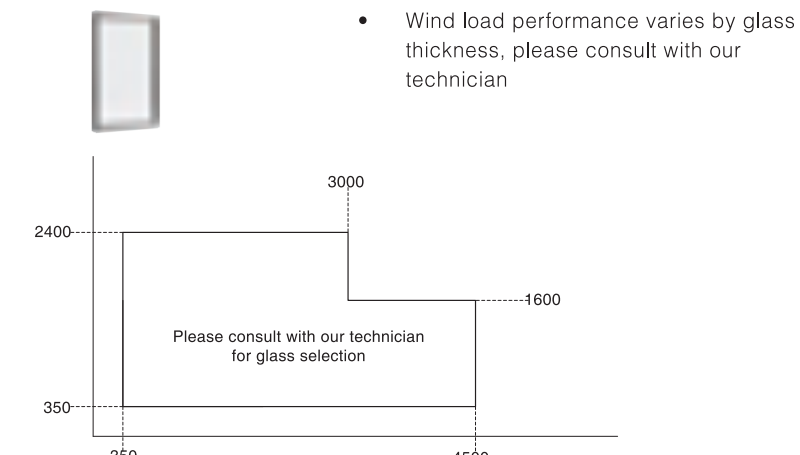

MIXED & COMBINATION WINDOW

- Mullions and Transoms are available for various windows and doors, Please consult with our sales representative for selection
- 180° mullion (standard and reinforced)

ATIS

WINDOW DOOR

OPTION MIX

- Available in SG and IG unit

SLIDING WINDOW (2 PANELS ON 2 TRACKS)

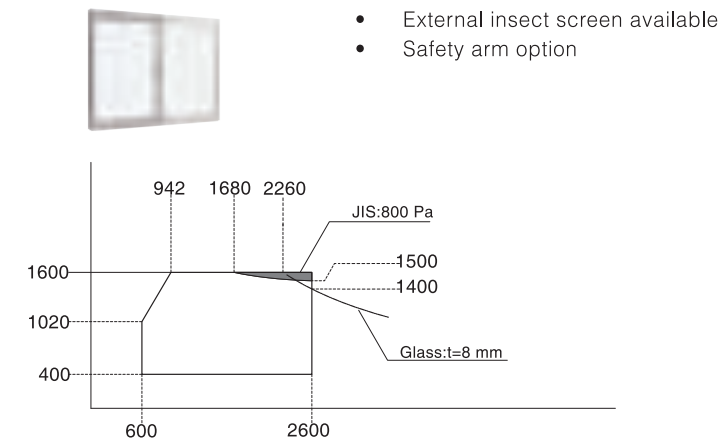

CASEMENT WINDOW (SINGLE LOCK)

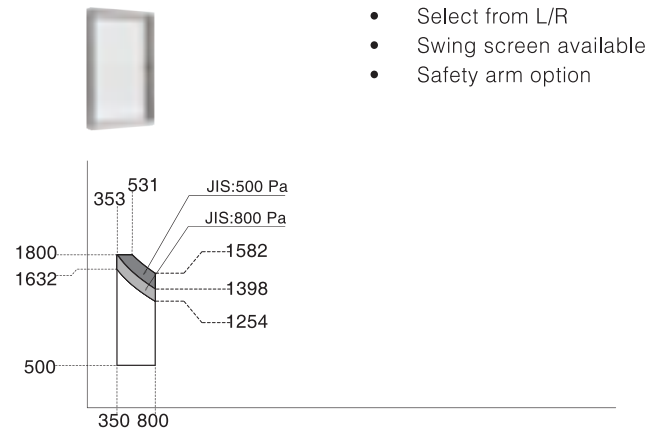

CASEMENT OPERATOR WINDOW

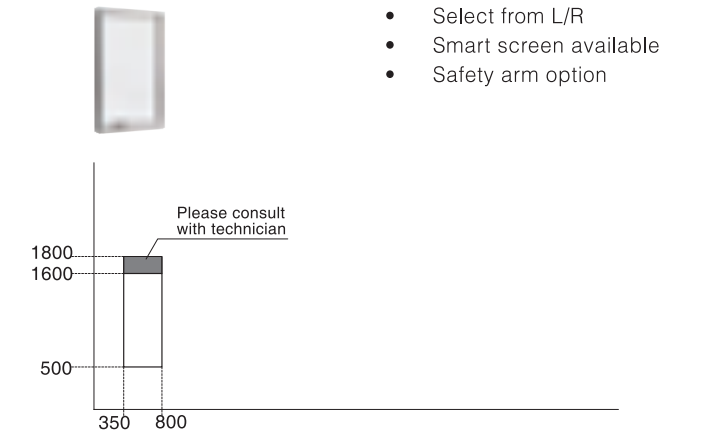

SLIDING WINDOW (4 PANELS ON 2 TRACKS)

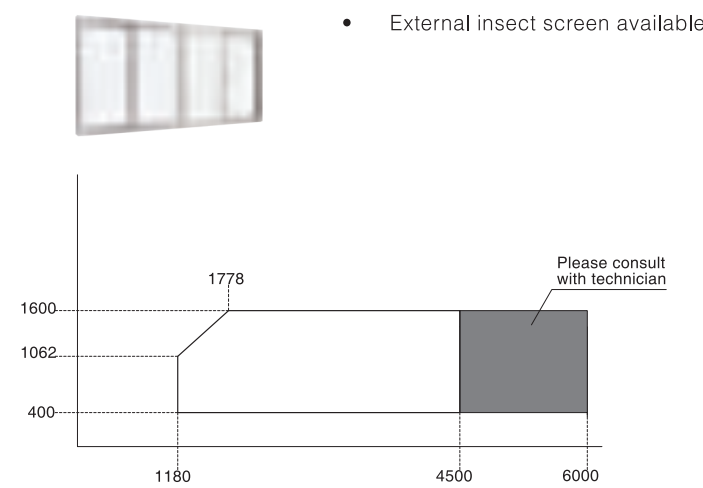

AWNING WINDOW (SINGLE LOCK)

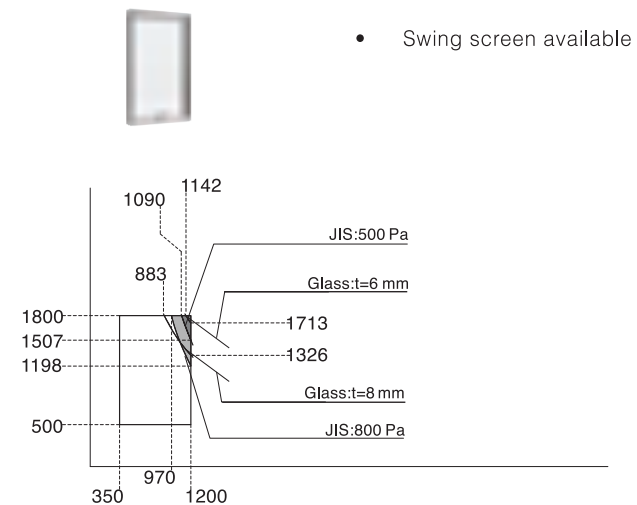

FIXED WINDOW

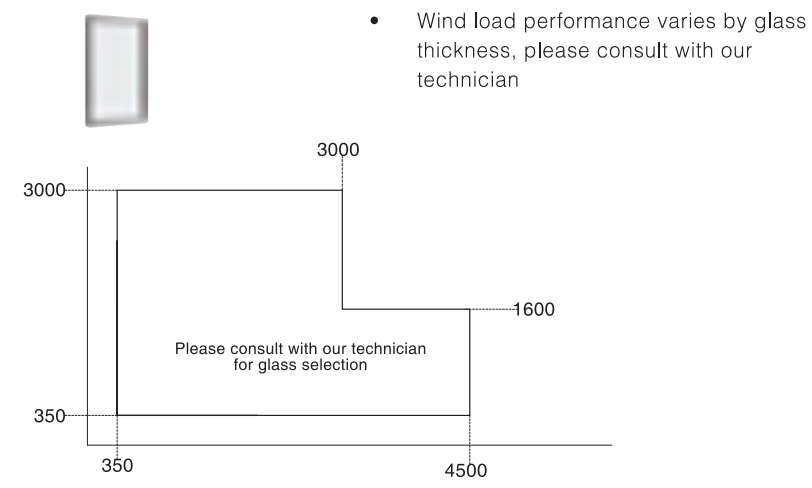

CORNER FIXED WINDOW

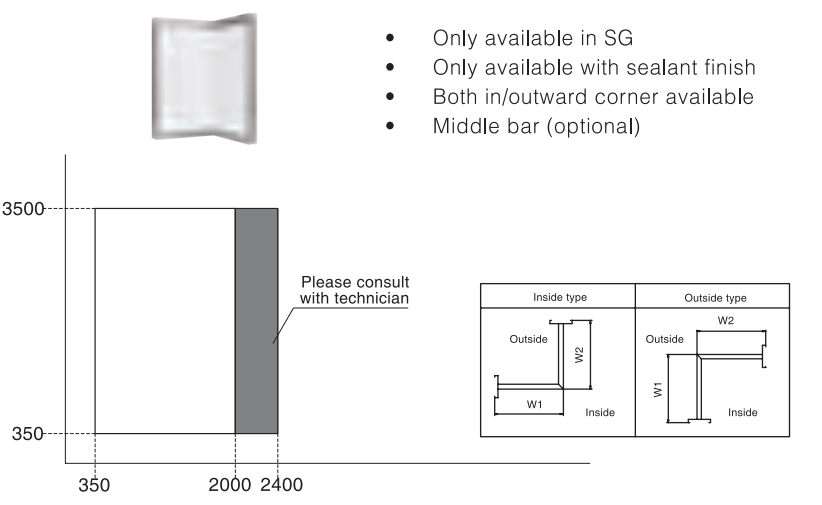

AWNING OPERATOR WINDOW

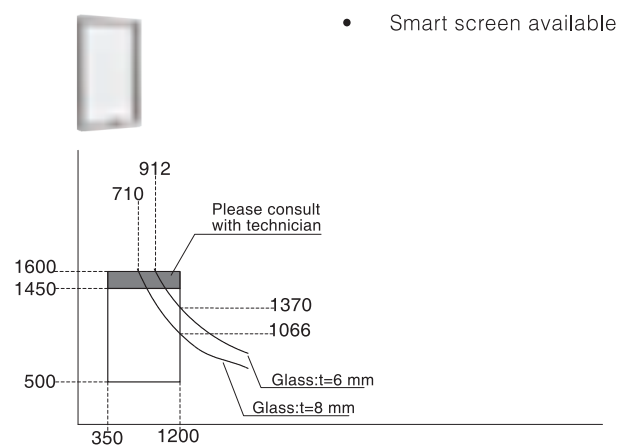

AWNING SLIT WINDOW

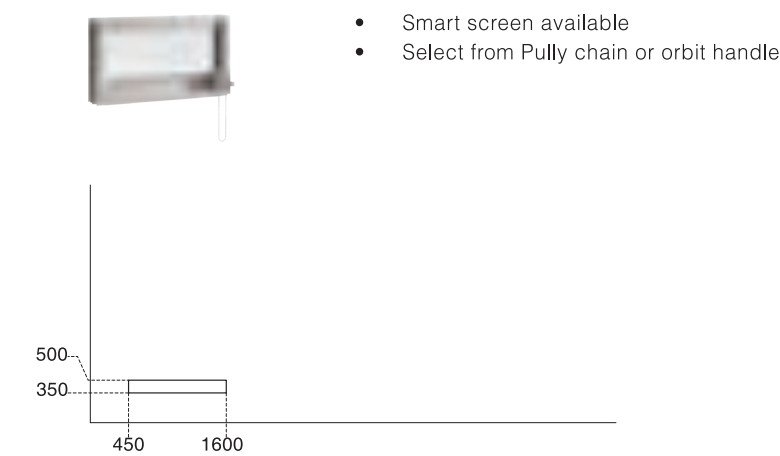

FIX UNIT VARIATION

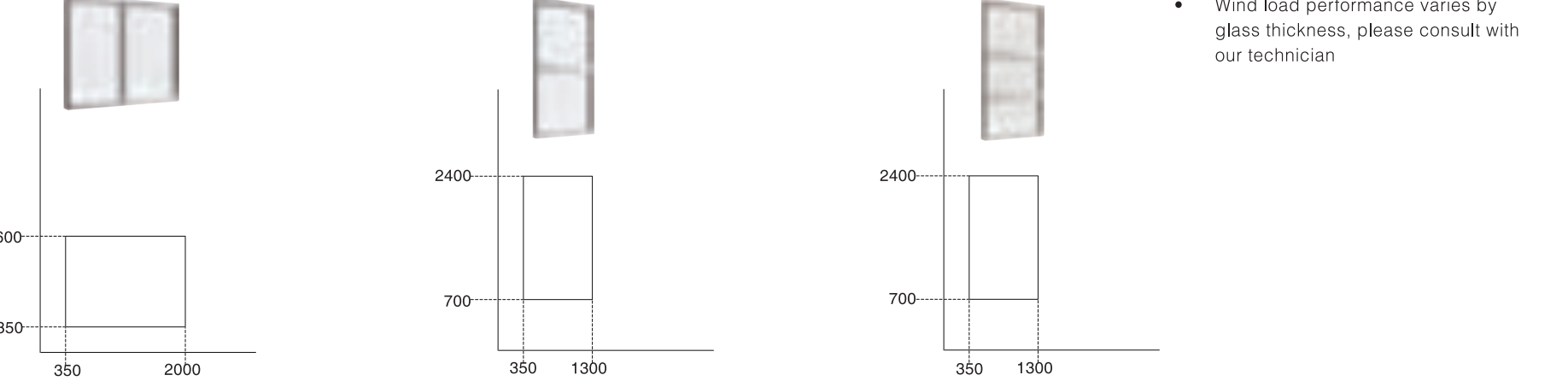

TILT & SLIDE



- External insect screen available

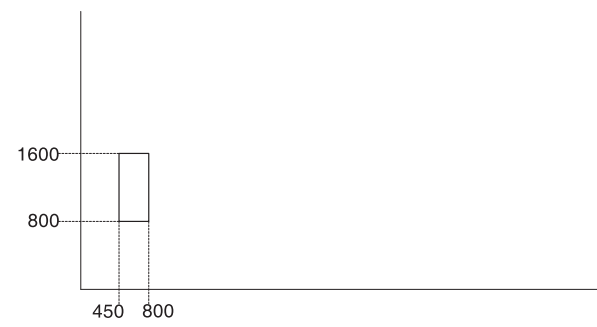

SLIDING DOOR (4 PANELS ON 2 TRACKS)

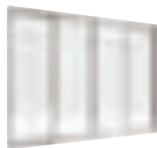

- External insect screen available
- Flat attachment option

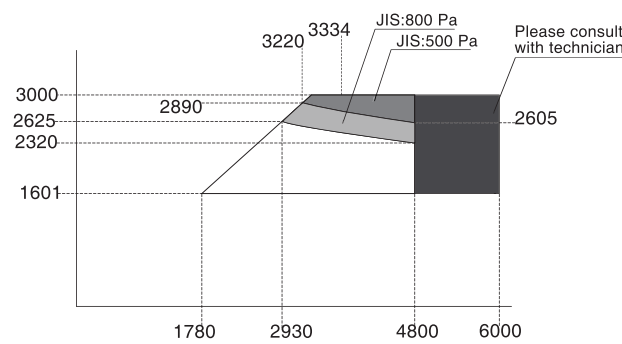

SLIDING DOOR (6 PANELS ON 3 TRACKS)



- External insect screen available

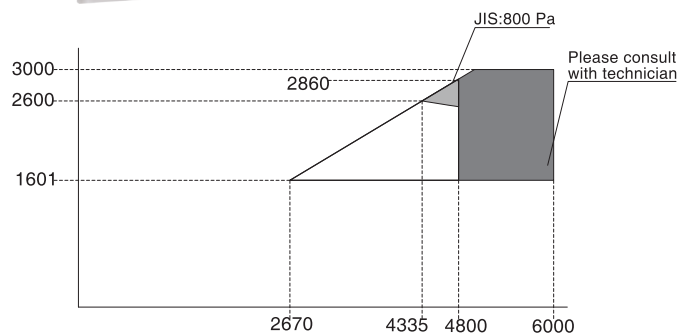

SLIDING DOOR (2 PANELS ON 2 TRACKS)



- External insect screen available
- Safety arm option
- Flat attachment option

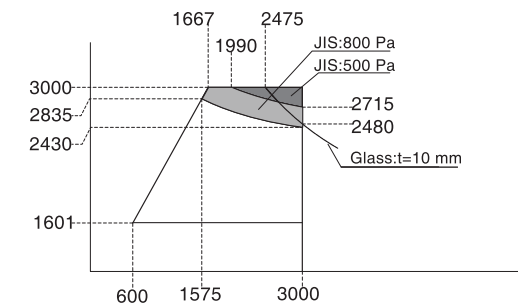

SLIDING DOOR (3 PANELS ON 3 TRACKS)



- External insect screen available

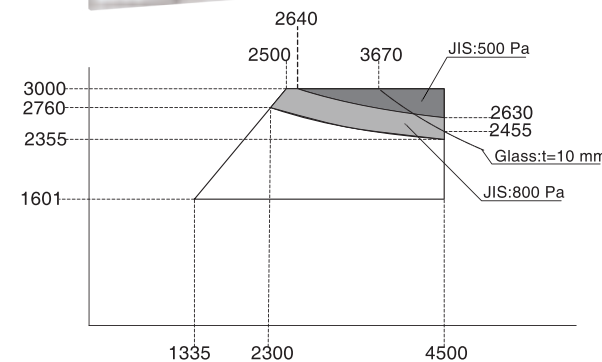

OUT-SWING DOOR (SINGLE)



- Door closer Not available
- Select from L/R

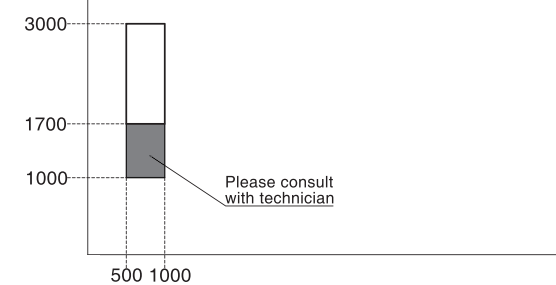

OUT-SWING DOOR (DOUBLE)



- Door closer Not available
- Select from L/R

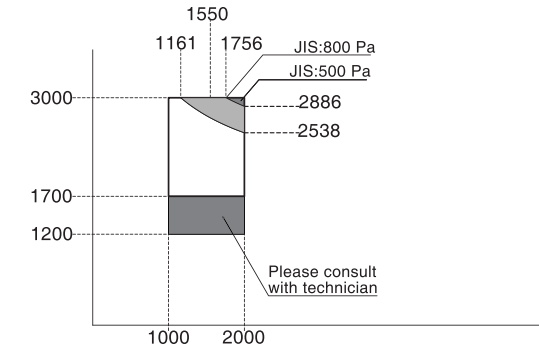

MIXED & COMBINATION WINDOW

- Mullions and Transoms are available for various windows and doors, Please consult with our sales representative for selection
- 180° mullion (standard and reinforced)
- 90° mullion (only for outward corner)





**ATIS PROJECT
REFERENCE**

A&B HOUSE, BANGKOK





WE SERIES

WE SERIES

COLOR



NATURAL WHITE



NATURAL SILVER



SHINE GRAY



AUTUMN BROWN



NATURAL BLACK



WE PLUS

WE PLUS has passed rigorous tests based on ASTM, and TOSTEM in-house's toughest standards. Available in various designs with a maximum height of 3 meters to satisfy various designers' needs in high-rise market.



SPECIFICATIONS

| | |
|-----------------|---|
| Frame Depth | 72 mm 104 mm (3 tracks sliding) |
| Height of Sill | 35 mm 50 mm (all slidings) |
| Glass Thickness | 5, 6, 8 mm (Panel: Single glass groove 11 mm) 8-13.52 mm (Panel: Laminated glass groove 17 mm) |

PERFORMANCES

WIND PRESSURE



1600 Pa
(ASTM E330)

WATER TIGHTNESS



240 Pa
(ASTM E331)

AIR TIGHTNESS



10.7m³ / h·m²
(ASTM E283)

NOISE INSULATION*



T-1 (25 dB)
(JIS A 1416)

* Sound performance test has been done in a JIS standard controlled environment. The performance will vary by room condition. Please consult with a sound insulation specialist.

WE 70

WE 70 series brings legendary TOSTEM quality to everyday life. Built for the mass market, yet maintaining strict quality standards. The WE 70 series is priced within everyone's reach.



SPECIFICATIONS

| | |
|-----------------|------------------------------------|
| Frame Depth | 72 mm 104 mm (3 tracks sliding) |
| Height of Sill | 35 mm |
| Glass Thickness | 5, 6, 8 mm |

PERFORMANCES

WIND PRESSURE



S-1 (800PA)
(JIS A 1515)

WATER TIGHTNESS



W-2 (150PA)
(JIS A 1517)

AIR TIGHTNESS



A-3 (8m³/h·m²)
(JIS A 1516)

NOISE INSULATION*



T-1 (25dB)
(JIS A 1416)

* Sound performance test has been done in a JIS standard controlled environment. The performance will vary by room condition. Please consult with a sound insulation specialist.

UNIQUE FEATURES

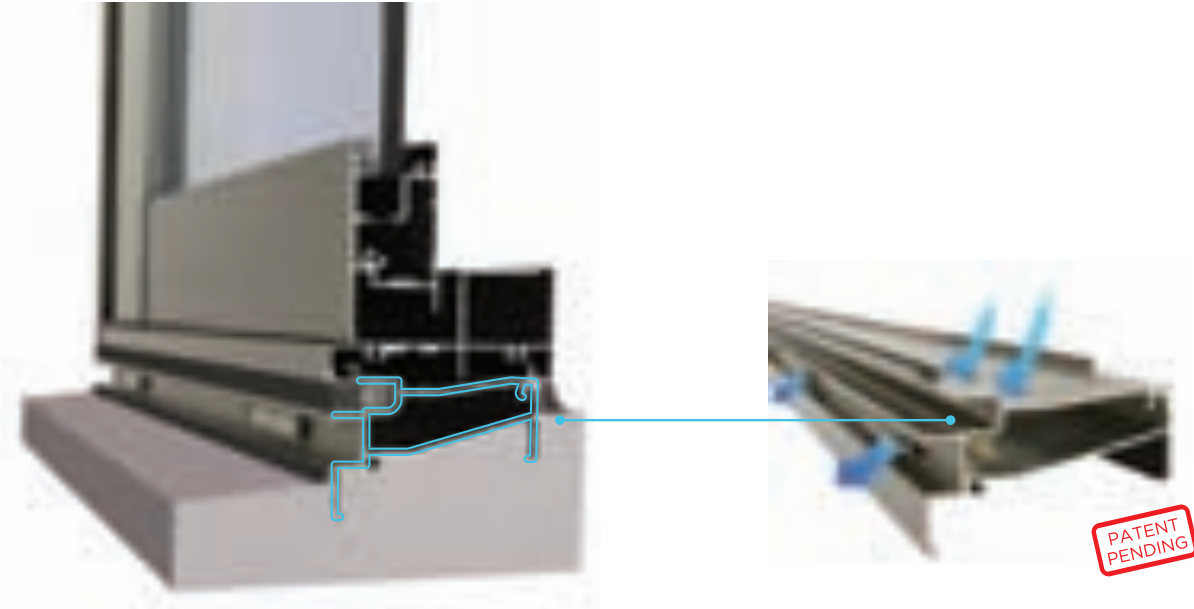

PRE-INSTALLED SILL ATTACHMENT FOR PRE-CAST CONCRETE (OPTION)

Attachment allows stability around windows for a longer time against the aged deterioration of a sealant. In case of water entry from outside sealant, attachment prevents water from penetrating inside.

*Only available for WE PLUS



WATERTIGHT SILL WITH DRAINAGE DEVICES

AIRFLOW SLOT



Smooth operation with bearing rollers



Air tightness: JIS A-3 when closed



Detachable insect screen for cleaning

Available with all windows

FOLDING DOOR



UNIQUE FEATURES



Watertight sill with drainage system



Flat sill is available and allows barrier-free passage

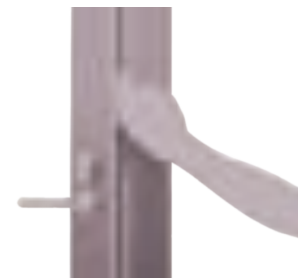

Smart designs prevent finger injuries



Hinge-less design

PRODUCT VARIETY (INSIDE VIEW)

| Panels | One way | Both ways | Center |
|-----------|---------|-----------|--------|
| 4 Panels | | | |
| 6 Panels | | | |
| 8 Panels | | | |
| 12 Panels | | | |
| 16 Panels | | | |

WE PLUS

- WINDOW** **DOOR**
- OPTION** **MIX**

SLIDING WINDOW (2 PANELS ON 2 TRACKS)



- Inside insect screen available

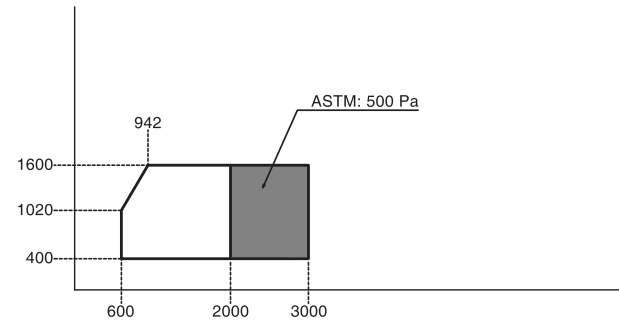

CASEMENT WINDOW (SINGLE LOCK)



- Insect screen available
- Select from L/R
- Safety arm (Optional)

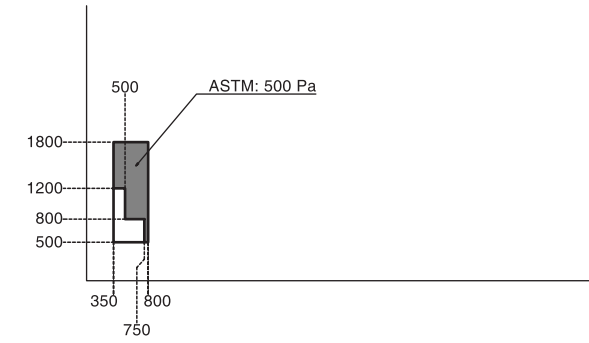

CASEMENT WINDOW (MULTI LOCK)



- Insect screen NOT available
- Select from L/R
- Safety arm (Optional)

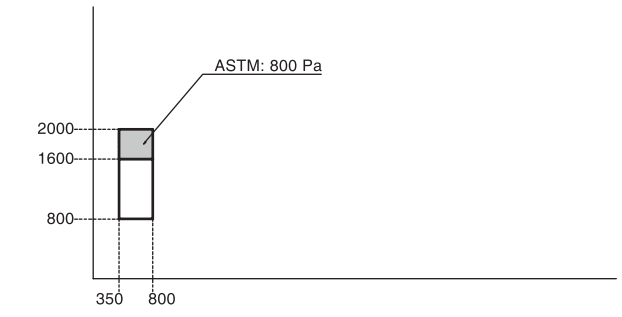

SLIDING WINDOW (4 PANELS ON 2 TRACKS)



- Inside insect screen available

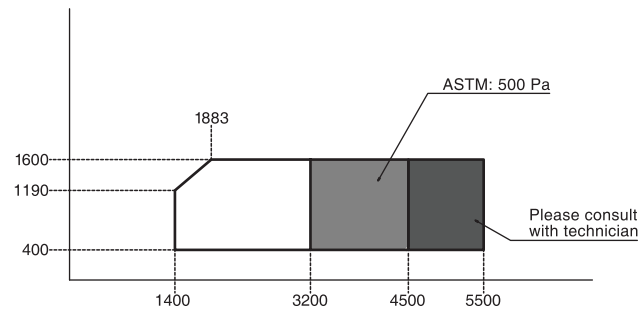

SLIDING WINDOW (3 PANELS ON 3 TRACKS)



- Inside insect screen NOT available

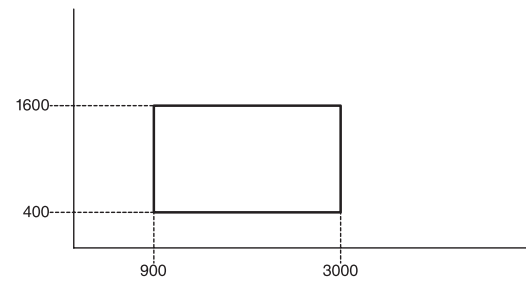

FIXED WINDOW



- Wind load performance varies by glass thickness, please consult with our technician

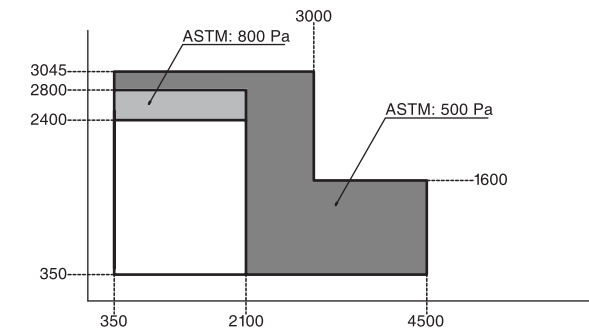

CORNER FIXED WINDOW



- Available only in outward corner
- Middle bar (optional)

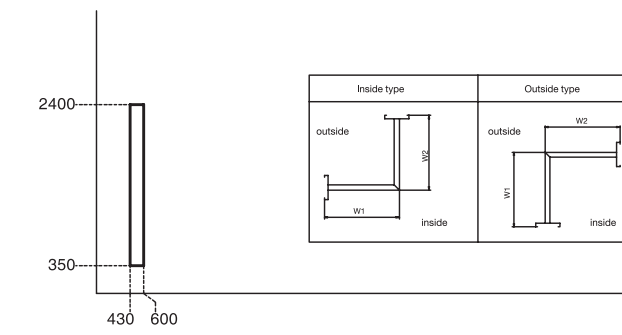

AWNING WINDOW (SINGLE LOCK)



- Insect screen available

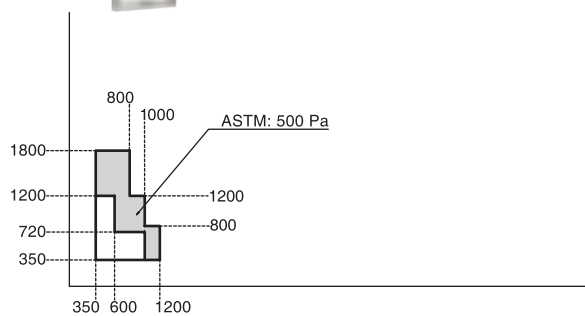

AWNING WINDOW (MULTI LOCK)



- Insect screen NOT available

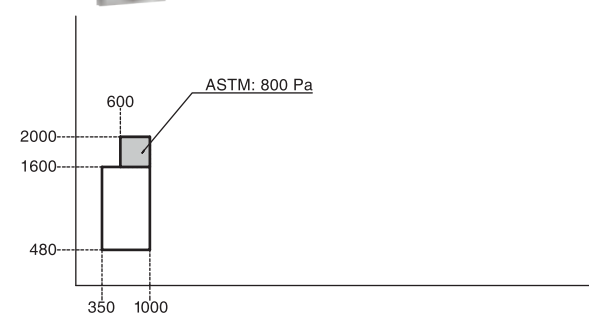

SLIDING DOOR (2 PANELS ON 2 TRACKS)



- Sill options (standard & floor finish)
- Inside insect screen available

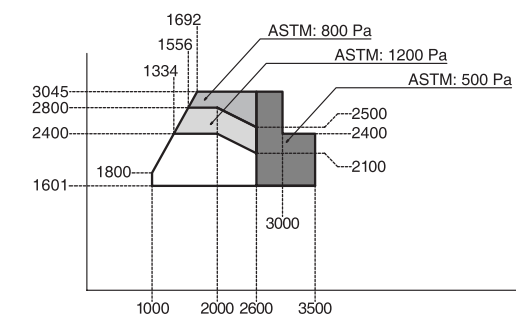

SLIDING DOOR (4 PANELS ON 2 TRACKS)



- Sill options (standard & floor finish)
- Inside insect screen available

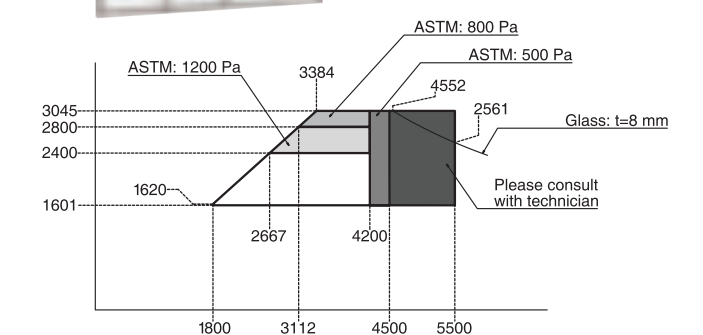

SLIDING DOOR (3 PANELS ON 3 TRACKS)

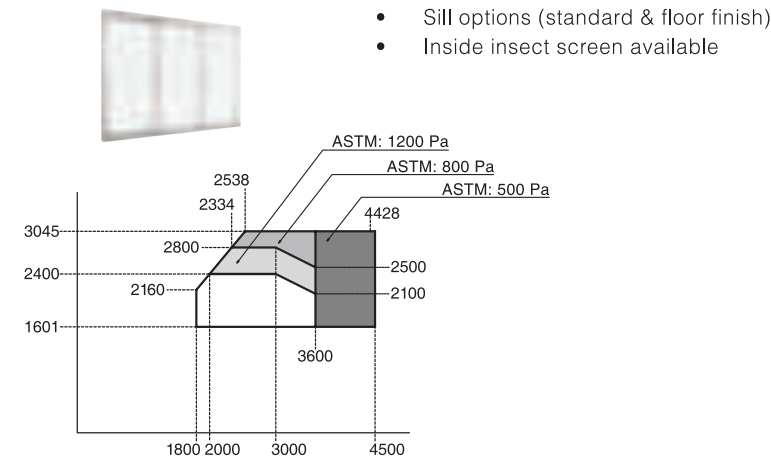

SLIDING DOOR (6 PANELS ON 3 TRACKS)

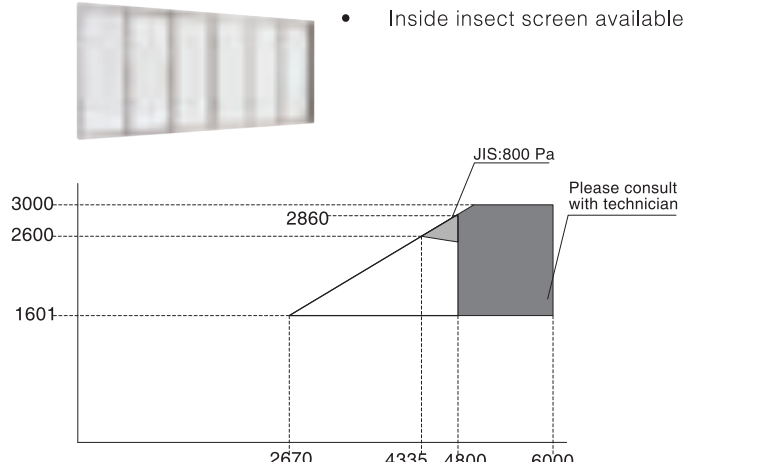

MIXED & COMBINATION WINDOW

- Mullions and transoms are available for each window and door, Please consult with our sales representative for selection
- 180° mullion (standard and reinforced)
- 90° mullion (only for outward corner)
- Transom (standard and reinforced)

UNIT WINDOWS

| Bottom Windows | Top Windows | | |
|-----------------|---------------|-----------------|-------------|
| | Single Awning | Single Casement | 1 Panel Fix |
| Single Awning | | | ● |
| Single Casement | | | ● |
| 1 Panel Fix | ● | ● | ● |

OUT – SWING DOOR (SINGLE)

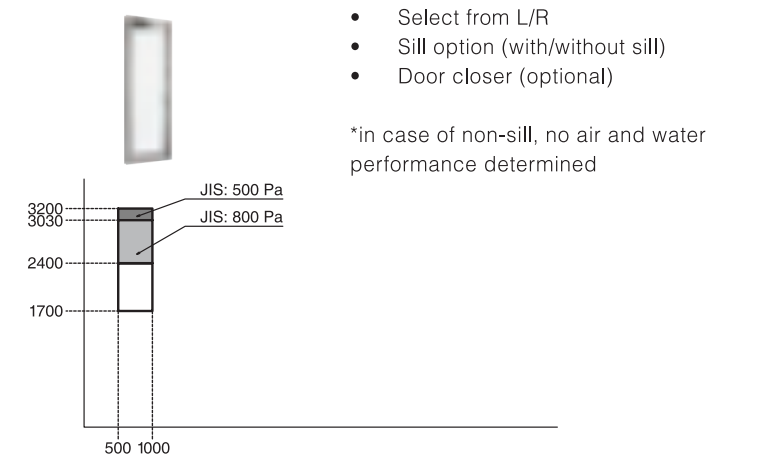

OUT-SWING DOOR (DOUBLE)

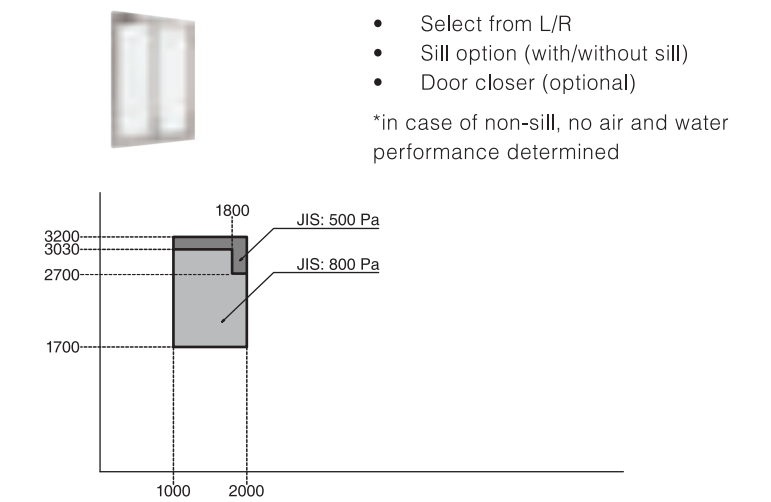

WE 70

WINDOW
DOOR

OPTION
MIX

- Airflow slots are available for windows only
- Windows on top of airflow slot shall be less than 25 Kg.
- Maximum length of airflow slot is 1500 mm (For windows wider than 1500 mm, use 2 or 3 airflow slots)

SLIDING WINDOW (2 PANELS ON 2 TRACKS)

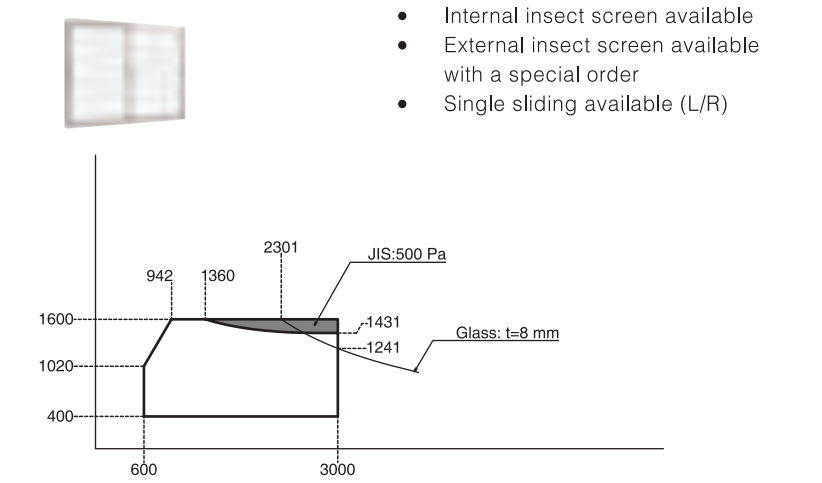

IN-SWING DOOR (SINGLE)

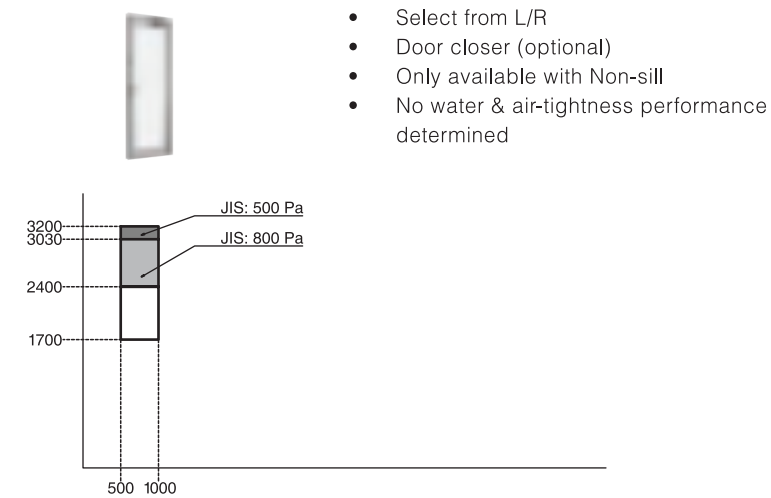

IN-SWING DOOR (DOUBLE)

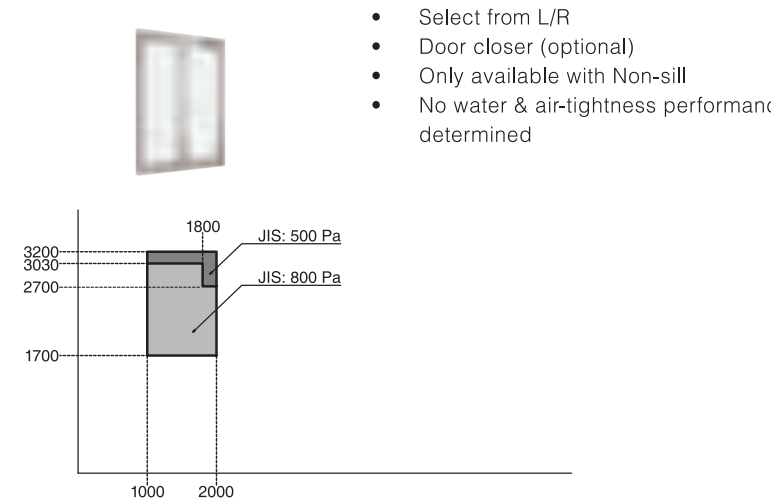

SLIDING WINDOW (4 PANELS ON 2 TRACKS)

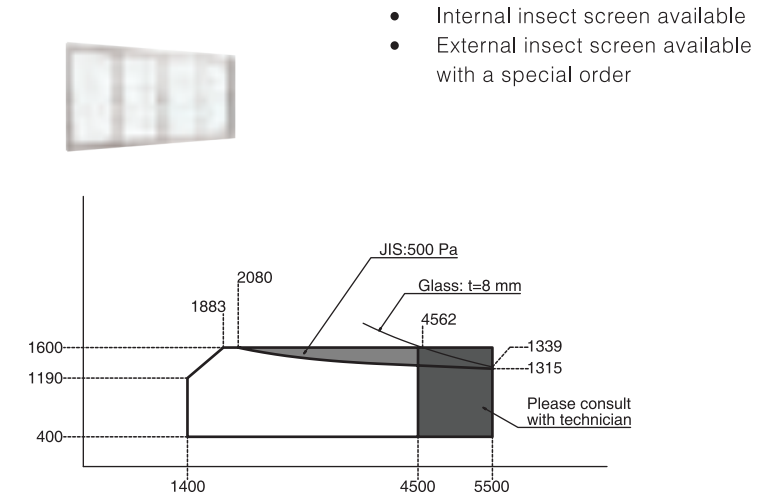

SLIDING WINDOW (3 PANELS ON 2 TRACKS) SFS

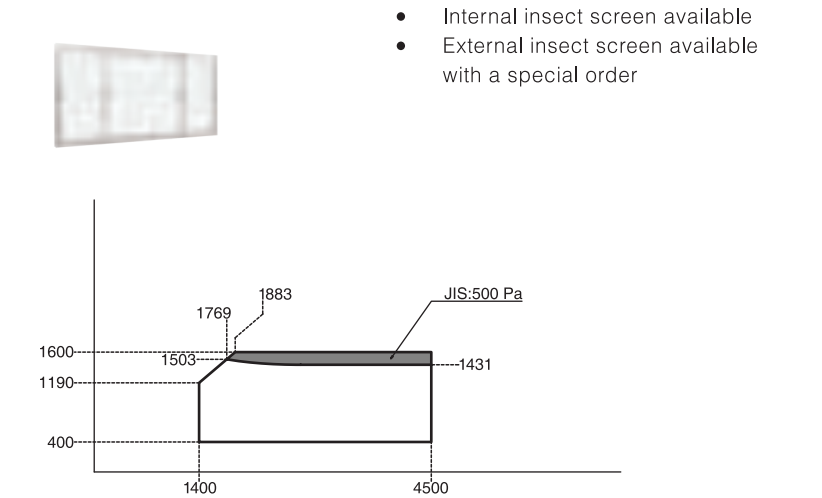

CASEMENT WINDOW



- Select from L/R
- Insect screen available

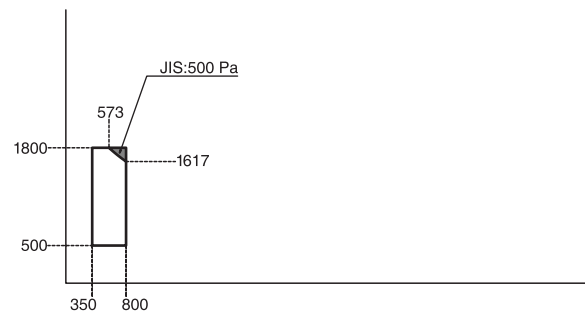

DOUBLE CASEMENT WINDOW



- Insect Screen available

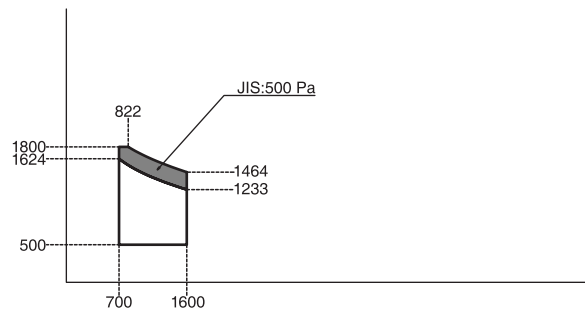

CORNER FIXED WINDOW



- Both In/outward corner available
- Middle bar (optional)

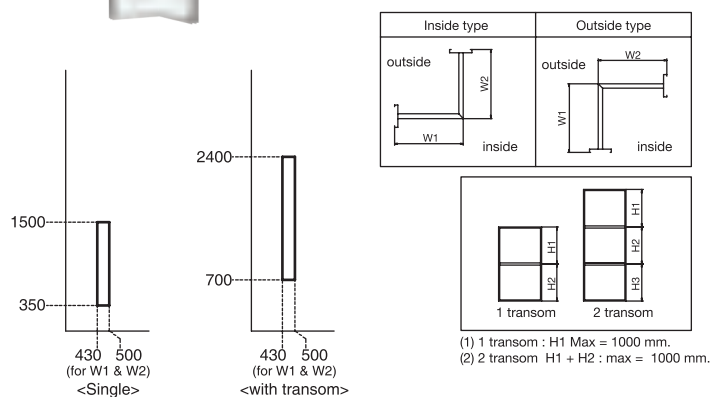

AWNING WINDOW



- Insect Screen available

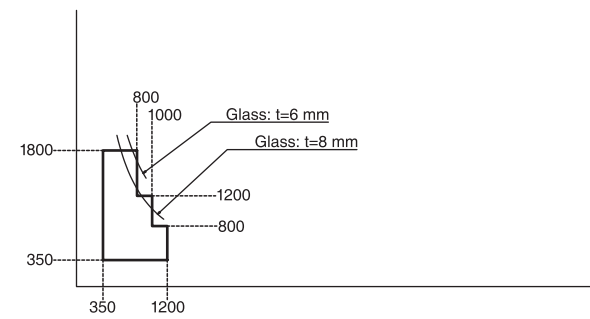

FIXED WINDOW



- Up to 4 fixed windows with unitized mullion
- Wind load performance varies by glass thickness Please consult with our technician

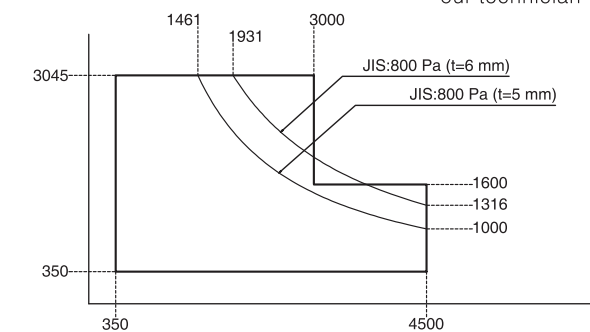

ALUMINIUM LOUVER



- No performance determined

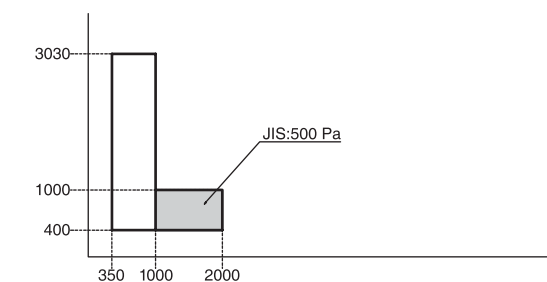

GLASS LOUVER



- Single, double, triple are available
- Insect screen available
- Water performance JIS: W-1 (100 Pa)
- * Please consult with our sales rep. for lead-time

| Size | Height (H) | | Width (W) | | |
|------|------------|---------|--------------------|---------------------|----------------------|
| | Blades | Handles | Single | Double | Triple |
| 0312 | 3 | 1 | Min 400 Max 800 | Min 801 Max 1600 | Min 1601 Max 2400 |
| 0401 | 4 | | | | |
| 0490 | 5 | | | | |
| 0579 | 6 | | | | |
| 0668 | 7 | | | | |
| 0757 | 8 | | | | |
| 0846 | 9 | | | | |
| 0935 | 10 | | | | |
| 1024 | 11 | | | | |
| 1113 | 12 | | | | |
| 1202 | 13 | | | | |
| 1291 | 14 | 2 | Min 400 Max 800 | Min 801 Max 1600 | Min 1601 Max 2400 |
| 1380 | 15 | | | | |
| 1469 | 16 | | | | |
| 1558 | 17 | | | | |
| 1647 | 18 | | | | |
| 1736 | 19 | 3 | Min 400 Max 800 | Min 801 Max 1600 | Min 1601 Max 2400 |
| 1825 | 20 | | | | |
| 1914 | 21 | | | | |
| 2003 | 22 | | | | |

SLIDING DOOR (4 PANELS ON 2 TRACKS)



- Sill options (standard & floor finish)
- Insect screen available (internal)

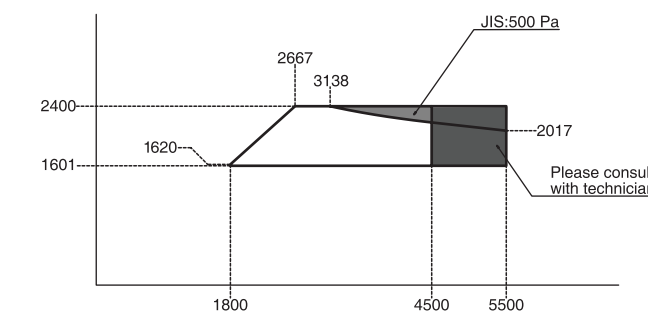

SLIDING DOOR (3 PANELS ON 3 TRACKS)



- Sill options (standard & floor finish)
- Insect screen available (internal)

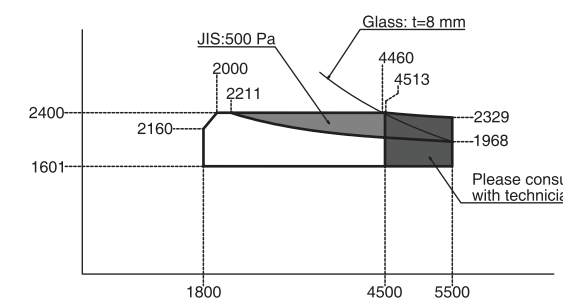

SLIDING DOOR (2 PANELS ON 2 TRACKS)



- Sill options (standard & floor finish)
- Single sliding available (L/R)
- Insect screen available (internal)

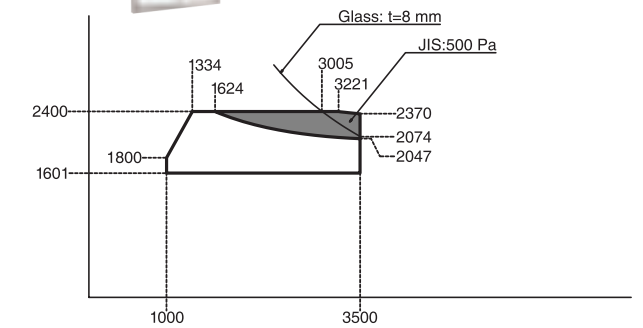

SLIDING DOOR (3 PANELS ON 2 TRACKS) SFS



- Sill options (standard & floor finish)
- Insect screen available (internal)

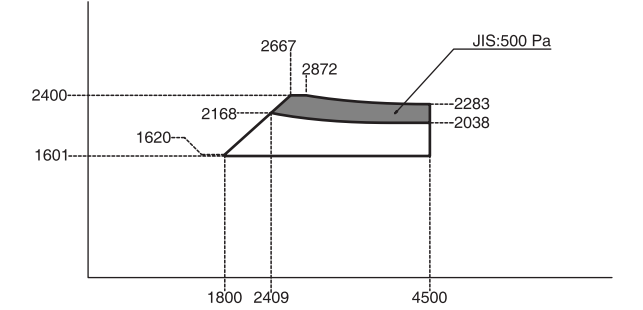

SLIDING DOOR (6 PANELS ON 3 TRACKS)



- Sill options (standard & floor finish)
- Insect screen available (internal)

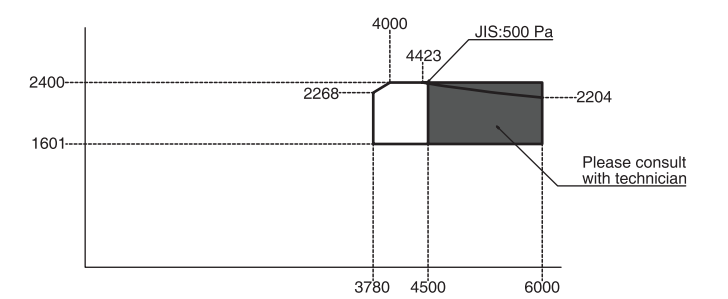

AIRFLOW DOOR



- Select from L/R
- Door closer (optional)
- Lattice with screen available

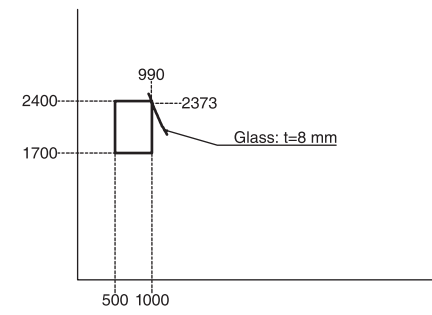

OUT-SWING DOOR (DOUBLE)

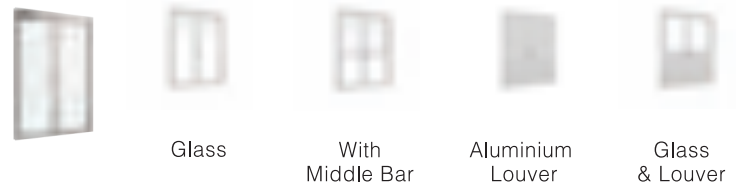

- Select from L/R
- Sill option (with/without sill)
- Door closer (optional)
- Insect screen available with louver door

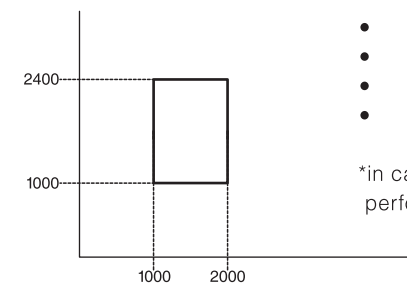

*in case of non-sill, no air and water performance determined

IN-SWING DOOR (DOUBLE)

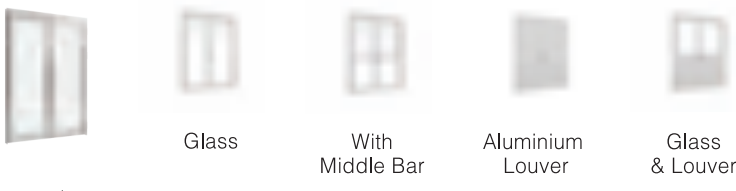

- Select from L/R
- Non-sill only
- Door closer (optional)
- Insect screen available with louver door
- No air and water performance determined

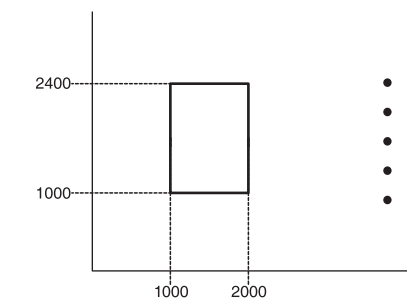

OUT-SWING DOOR (SINGLE)

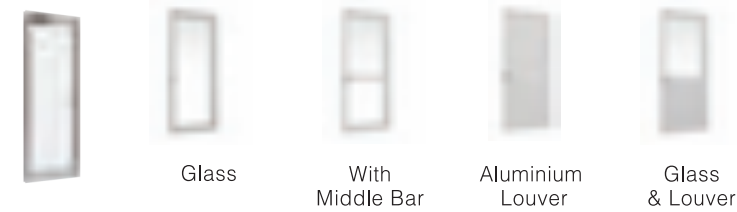

- Select from L/R
- Sill option (with/without sill)
- Door closer (optional)
- Insect screen available with louver door

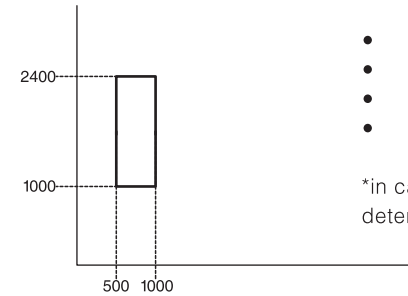

*in case of non-sill, no air and water performance determined

IN-SWING DOOR (SINGLE)

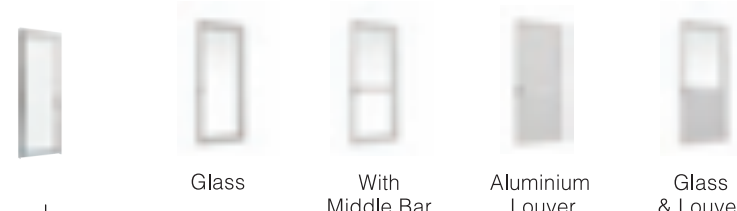

- Select from L/R
- Non-sill only
- Door closer (optional)
- Insect screen available with louver door
- No air and water performance determined

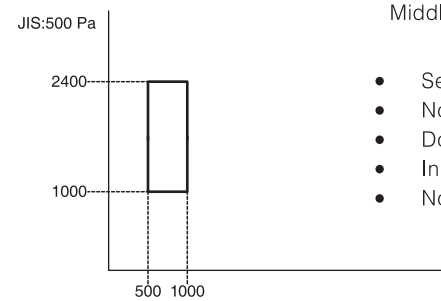

FOLDING DOOR (4 PANELS)



- Sill option (standard & flat)
- 1 panel weight cannot exceed 40 Kg.
- 1 panel width limit 350 - 850 mm
- Choose from
 - One way open (select L/R)
 - Both ways open
 - Center open

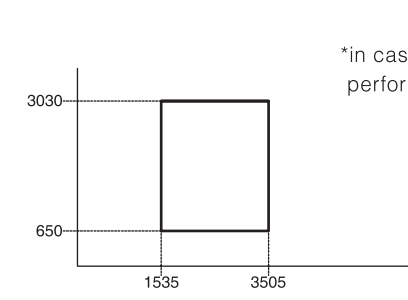

*in case of flat-sill, no air and water performance determined

FOLDING DOOR (6 PANELS)



- Sill option (standard & flat)
- 1 panel weight cannot exceed 40 Kg.
- 1 panel width limit 350 - 850 mm
- Choose from
 - One way open (select L/R)
 - Both ways open
 - Center open

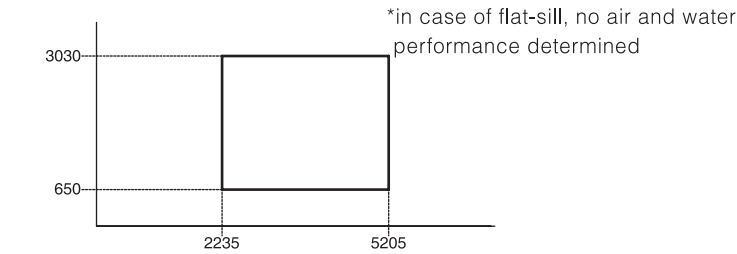

*in case of flat-sill, no air and water performance determined

FOLDING DOOR (12,16 PANELS)

- Sill option (standard & flat)
- 1 panel weight cannot exceed 40 Kg.
- 1 panel width limit 350 - 850 mm
- Center open only
- No air and water performance determined

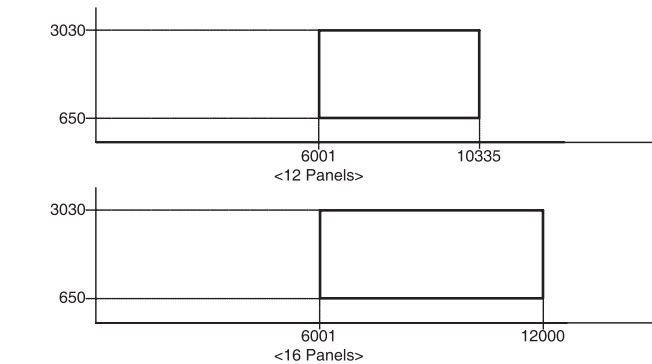

FOLDING DOOR (8 PANELS)

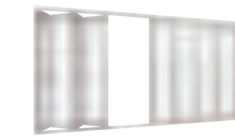

- Sill option (standard & flat)
- 1 panel weight cannot exceed 40 Kg.
- 1 panel width limit 350 - 850 mm
- Choose from
 - One way open (select L/R)
 - Both ways open
 - Center open
- Water performance is JIS: 120 pa

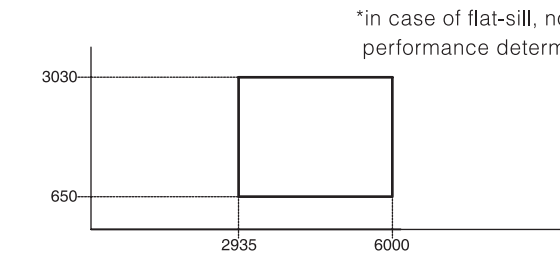

*in case of flat-sill, no air and water performance determined

ENTRANCE SLIDING DOOR (2 PANELS ON 2 TRACKS)



- Sill options (standard & floor finish)
- Single sliding available (L/R)
- External Insect screen available

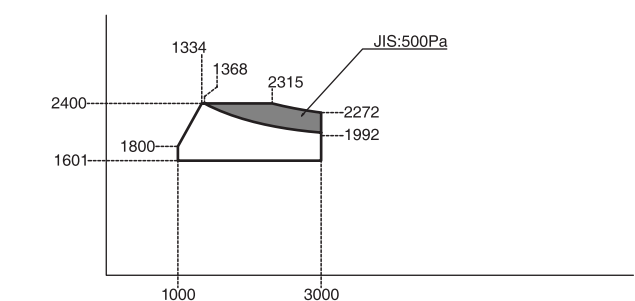

ENTRANCE SLIDING DOOR (4 PANELS ON 2 TRACKS)



- Sill options (standard & floor finish)
- External Insect screen available

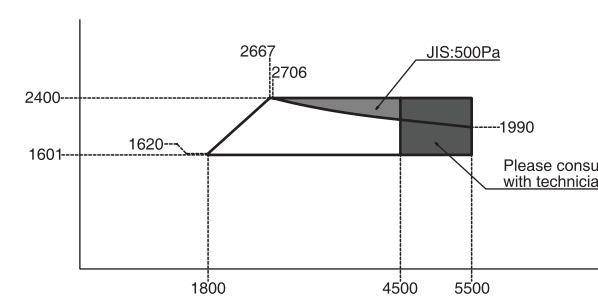

Please consult with technician

MIXED & COMBINATION WINDOW

- Mullions and transoms are available for each window and door, please consult with our sales representative for selection
- 180° mullion (standard)
- 90° mullion (only for outward corner)
- Transom (standard)

UNIT WINDOWS

| Bottom Windows | Top Windows | | | | | | | | | | | |
|---|---------------------------------------|---------------------------------------|---|---------------|-----------------|-----------------|-------------|--------------|--------------|--------------|--------------------|-------------------|
| | Sliding Window (2 Panels on 2 Tracks) | Sliding Window (4 Panels on 2 Tracks) | Sliding Window (3 Panels on 2 Tracks) SFS | Single Awning | Single Casement | Double Casement | 1 Panel Fix | 2 Panels Fix | 3 Panels Fix | 4 Panels Fix | Outward-Corner Fix | Inward-Corner Fix |
| Sliding Window (2 Panels on 2 Tracks) | | | | | | | • | • | | | | |
| Sliding Window (4 Panels on 2 Tracks) | | | | | | | | • | • | • | | |
| Sliding Window (3 Panels on 2 Tracks) SFS | | | | | | | | • | • | • | | |
| Single Awning | | | | | | | • | | | | | |
| Single Casement | | | | | | | • | | | | | |
| Double Casement | | | | | | | • | • | | | | |
| 1 Panel Fix | • | | | • | • | • | • | | | | | |
| 2 Panels Fix | • | • | • | | | • | | • | • | • | | |
| 3 Panels Fix | | • | • | | | | • | • | • | • | | |
| 4 Panels Fix | | • | • | | | | • | • | • | • | | |
| Outward-Corner Fix | | | | | | | | | | • | | |
| Inward-Corner Fix | | | | | | | | | | | | • |

UNIT DOORS

| Bottom Doors | Top Windows | | | |
|---|-------------|--------------|--------------|--------------|
| | 1 Panel Fix | 2 Panels Fix | 3 Panels Fix | 4 Panels Fix |
| Sliding Door (2 Panels on 2 Tracks) | • | • | | |
| Sliding Door (4 Panels on 2 Tracks) | | • | • | • |
| Sliding Door (3 Panels on 2 Tracks) SFS | | • | • | • |
| 2 Panels Fix | | • | • | • |
| 3 Panels Fix | | • | • | • |
| 4 Panels Fix | | • | • | • |
| Swing Door (Single) | • | | | |
| Swing Door (Double) | | • | | |





**WE SERIES
PROJECT
REFERENCE**

THE ARTIQUE, BANGKOK

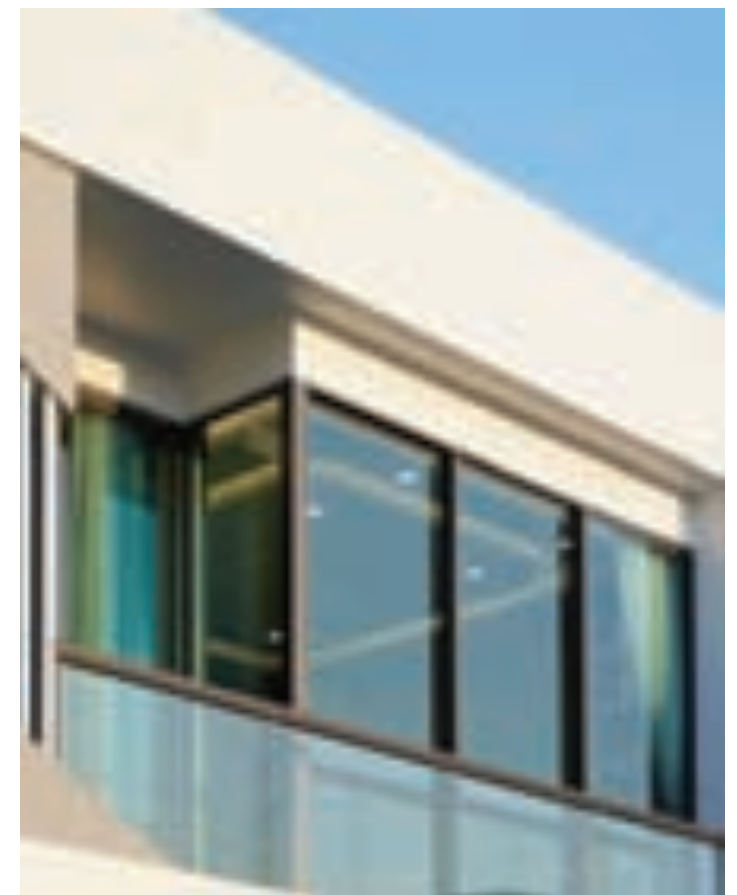



INTERIOR SERIES

INTERIOR SERIES

INTERIOR Series, a luxurious and durable choice to divide interior living spaces. Available are the hanging type without floor track, sliding type with floor track, and swing type. Slim design Aluminum profiles give a modern accent to your space.

SPECIFICATIONS

| | | Hanging Door | Sliding Door |
|-----------------|----------|-----------------------------|-------------------|
| Frame Depth | 1 track | Top 47.2 mm Jamb 49.1 mm | 72 mm (2 tracks) |
| | 2 tracks | Top 47.2 mm Jamb 49.1 mm | 104 mm (3 tracks) |
| Height of Sill | | No sill | 20 mm |
| Glass Thickness | | 5, 6, 8 mm | 5, 6, 8 mm |



COLOR



FEATURES



EFFORTLESS MOVEMENT



SAFETY

UNIQUE FEATURES



DURABLE ROLLERS FOR SMOOTH OPERATION



SOFT CLOSE FOR EXTRA SAFETY (OPTION)



PULL (STANDARD)



HANDLE & LOCK-SET (OPTION IN SILVER ONLY)



SILL-LESS DESIGN PROVIDES SAFETY AND COMFORT FOR ALL



PANEL GUIDE PIECE TO PREVENT PANEL FROM SHAKING WHEN SLIDING

INTERIOR SERIES

- WINDOW
- DOOR
- OPTION
- MIX

ON-WALL HANGING DOOR (2 PANELS ON 1 TRACK)

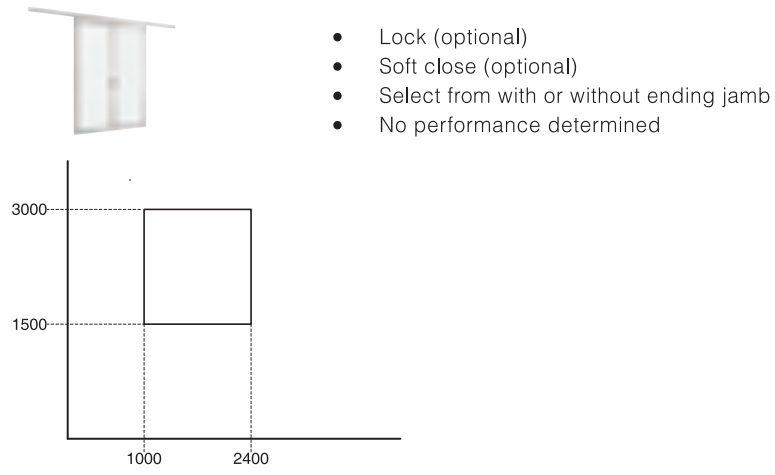

PARTITION DOOR (3 PANELS ON 3 TRACKS)

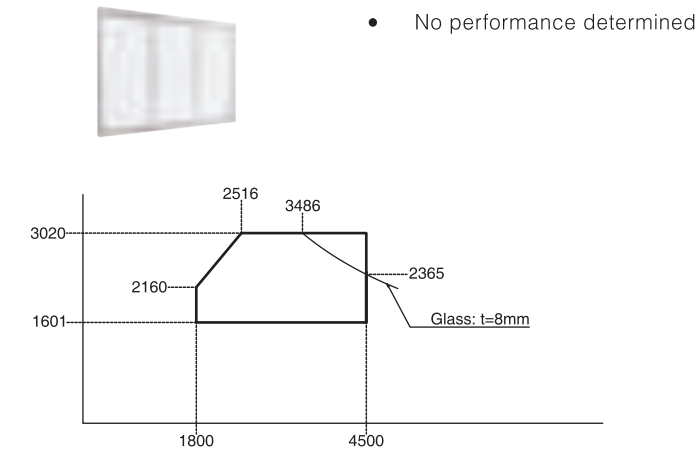

ON-WALL HANGING DOOR (1 PANEL ON 1 TRACK)

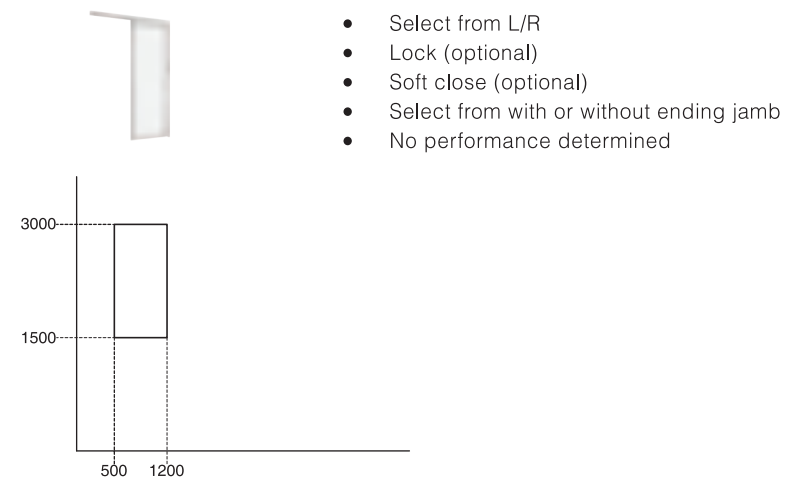

HANGING DOOR (2 PANELS ON 2 TRACKS)

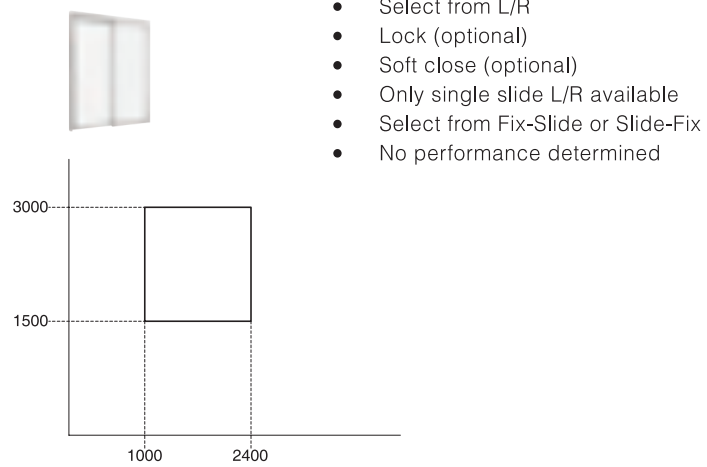

PARTITION DOOR (4 PANELS ON 2 TRACKS)

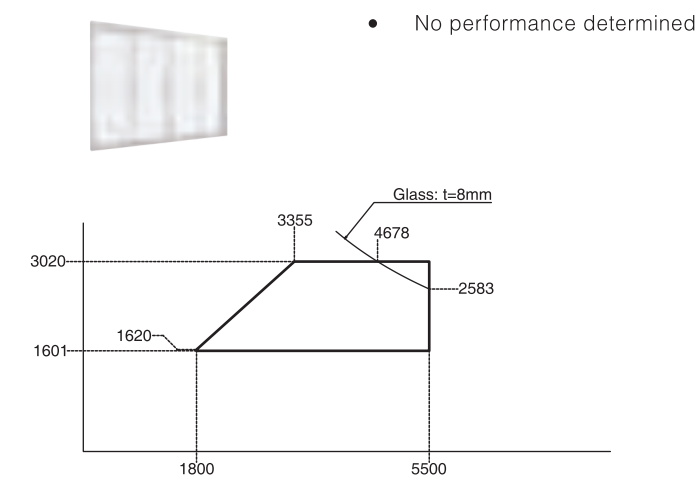

IN-WALL HANGING DOOR (1 PANEL ON 1 TRACK)

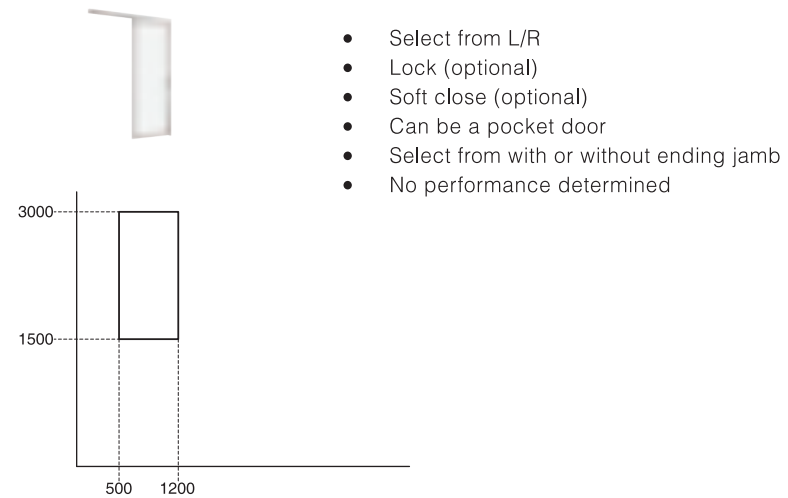

PARTITION DOOR (2 PANELS ON 2 TRACKS)

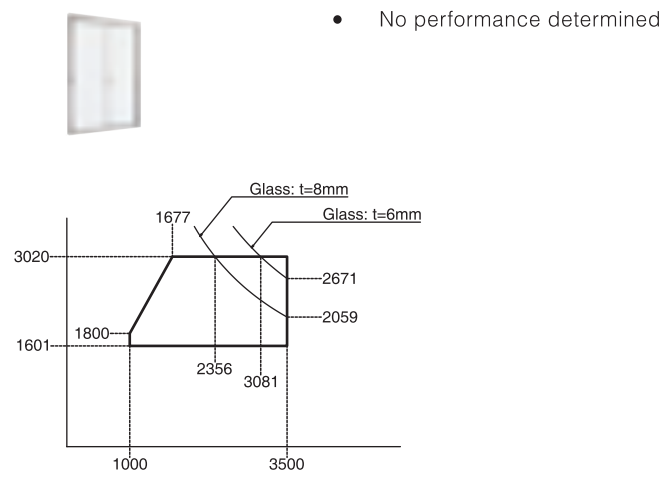

PARTITION DOOR (6 PANELS ON 3 TRACKS)

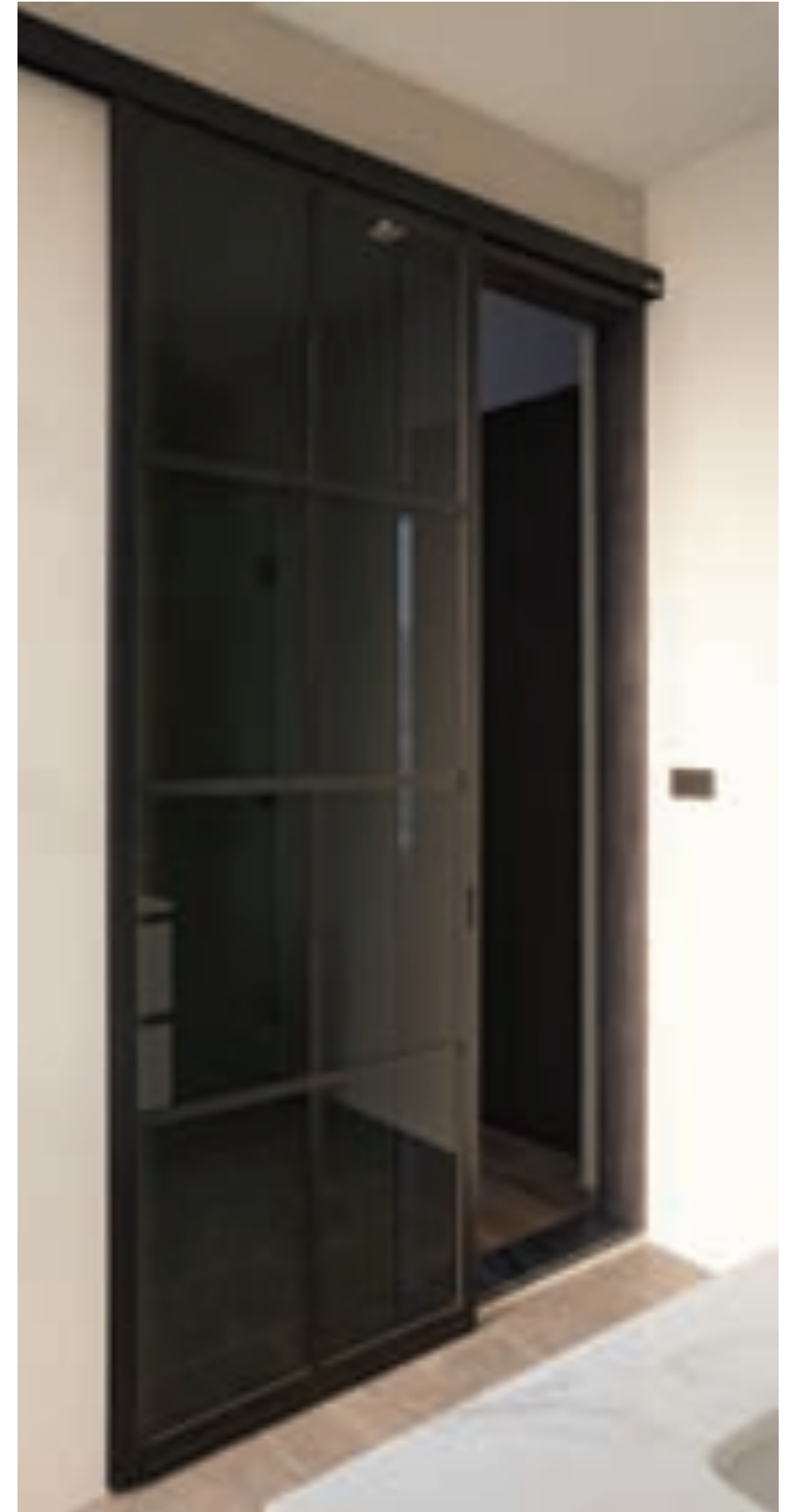
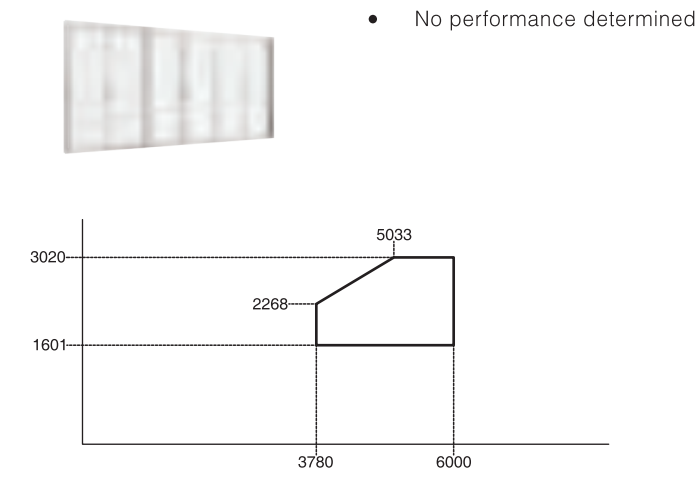



ENTRANCE DOOR



GIESTA SERIES

High quality wood-pattern or metallic-finish doors equipped with user-friendly handle with high security lock system gives better convenience to both family and visitors and make you feel glad to be home.

UNIQUE FEATURES

SPECIFICATIONS

| | |
|----------------|---|
| Frame Depth | 101.6 mm |
| Height Of Sill | Out-Swing 50 mm |
| | In-Swing Outside 30 / Inside 14 mm |
| Door Frame | TOP AND SIDE FRAME <ul style="list-style-type: none"> Wood pattern type: Wood pattern resin sheet, wrapping on Aluminum profile with synthetic rubber Painted type Anodized Aluminum profile |
| | SILL Anodized Aluminum profile |
| Door Panel | EXTERNAL SHEET <ul style="list-style-type: none"> Wood pattern type : (External) Steel Panels with Resin laminated sheet/ (Internal) Anti-rust epoxy coating Polystyrene (EPS Foam) |
| | Insulating glass thickness 23 mm (Cleared 3+Air gap 16+Patterned glass 4) |

PERFORMANCES

WIND PRESSURE



S-2 (1200PA)
(JIS A 1515)

WATER TIGHTNESS



W-2 (150PA)
(JIS A 1517)

AIR TIGHTNESS



A-4 (2)
(JIS A 1516)

NOISE INSULATION



N/A
(JIS A 1416)



SIMPLE AND MINIMALISTIC

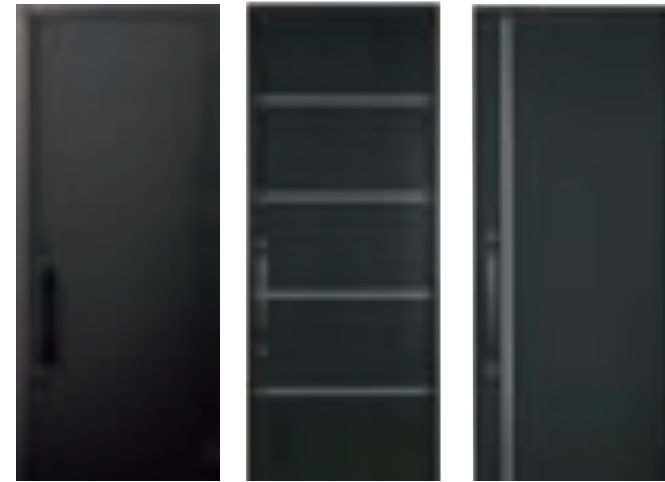

P01

P02

P03

COLORS



TURIN PINE

CREA MOCHA

CREA RUSK

TEAK





POLISH SILVER

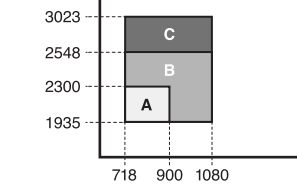
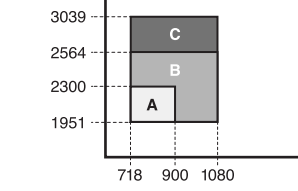
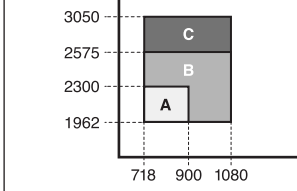
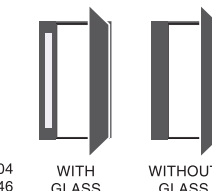
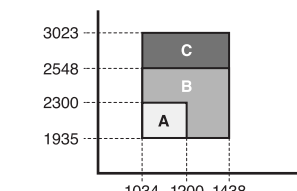
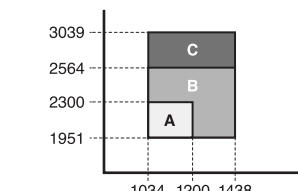
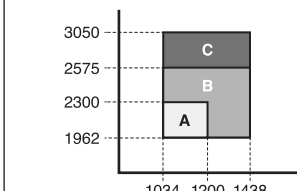

SILKY WHITE

AUTUMN BROWN

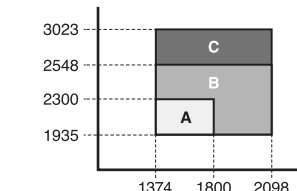
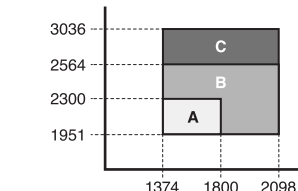
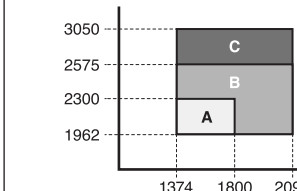

| Wood Pattern | In-Swing (no sill) | In-Swing | Out-Swing |
|---|---|---|---|
| SINGLE  |  |  |  |
| WITH SIDELIGHT Width of sidelight [SW] 1034 < W 1248 : SW = 304 1249 < W 1438 : SW = 346  |  |  |  |
| DOUBLE  |  |  |  |

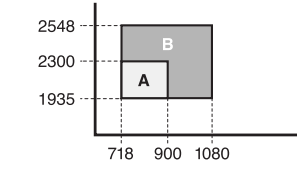
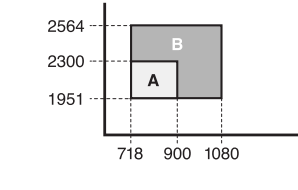
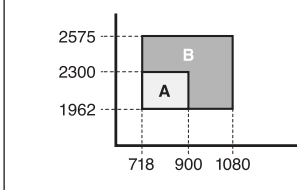
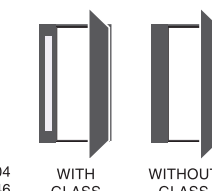
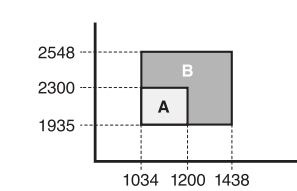
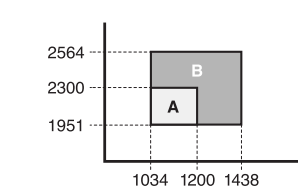
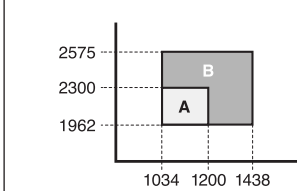

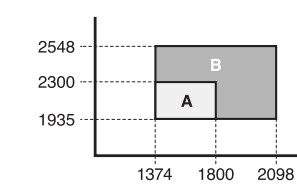
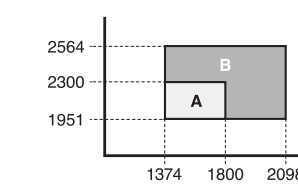
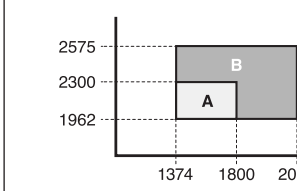
| Aluminum Pattern | In-Swing (no sill) | In-Swing | Out-Swing |
|---|---|---|---|
| SINGLE  |  |  |  |
| WITH SIDELIGHT Width of sidelight [SW] 1034 < W 1248 : SW = 304 1249 < W 1438 : SW = 346  |  |  |  |
| DOUBLE  |  |  |  |

*A, B, C indicates price changing points. (A<B<C)

MODERN BUT TRADITIONAL



D01

D02

D03

COLORS



TURIN PINE

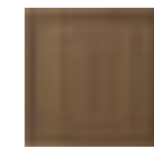

CREA MOCHA





CREA RUSK



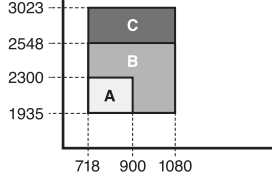
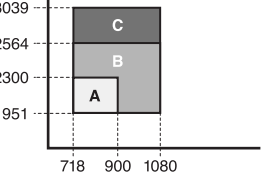
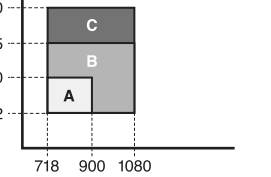
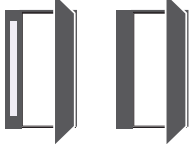
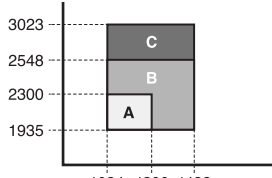
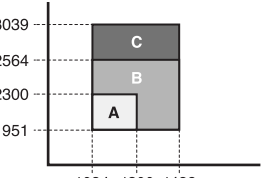
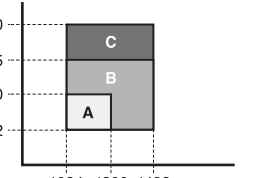

TEAK

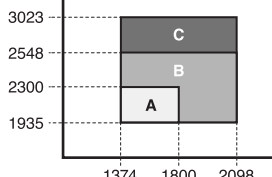
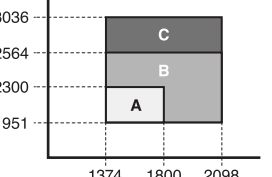
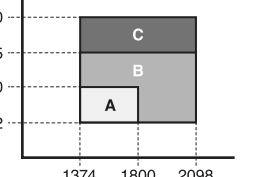

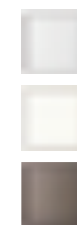
| Wood Pattern | In-Swing (no sill) | In-Swing | Out-Swing |
|---|---|---|---|
| SINGLE  |  |  |  |
| WITH SIDELIGHT Width of sidelight [SW] 1034 < W 1248 : SW = 304 1249 < W 1438 : SW = 346  |  |  |  |
| DOUBLE  |  |  |  |



| Aluminum Pattern | In-Swing (no sill) | In-Swing | Out-Swing |
|---|--------------------|----------|-----------|
| SINGLE  | N/A | N/A | N/A |
| WITH SIDELIGHT Width of sidelight [SW] 1034 < W 1248 : SW = 304 1249 < W 1438 : SW = 346  | N/A | N/A | N/A |
| DOUBLE  | N/A | N/A | N/A |

*A, B, C indicates price changing points. (A<B<C)

GLASS WITH STYLE



G01 G02 G03 G04

COLORS



TURIN PINE CREA MOCHA CREA RUSK TEAK



POLISH SILVER SILKY WHITE AUTUMN BROWN



| Wood Pattern | In-Swing (no sill) | In-Swing | Out-Swing |
|--|--|--|--|
| SINGLE | 3023 2548 2300 1935 (2235) 718 (668) 900 1080 | 3039 2564 2300 1951 (2251) 718 (668) 900 1080 | 3050 2575 2300 1962 (2262) 718 (668) 900 1080 |
| WITH SIDELIGHT Width of sidelight [SW] (1184) 1034 < W 1248 : SW = 304 1249 < W 1438 : SW = 346 WITH GLASS WITHOUT GLASS | 3023 2548 2300 1935 (2235) 1034 1200 1438 (1184) | 3039 2564 2300 1951 (2251) 1034 1200 1438 (1184) | 3050 2575 2300 1962 (2262) 1034 1200 1438 (1184) |
| DOUBLE | 3023 2548 2300 1935 (2235) 1374 (1674) 1800 2098 | 3036 2564 2300 1951 (2251) 1374 (1674) 1800 2098 | 3050 2575 2300 1962 (2262) 1374 (1674) 1800 2098 |

*Dimension indicated in () are the minimum dimension for G01 design



| Aluminum Pattern | In-Swing (no sill) | In-Swing | Out-Swing |
|---|--|--|--|
| SINGLE | 2548 2300 1935 718 900 1080 | 2564 2300 1951 718 900 1080 | 2575 2300 1962 718 900 1080 |
| WITH SIDELIGHT Width of sidelight [SW] 1034 < W 1248 : SW = 304 1249 < W 1438 : SW = 346 WITH GLASS WITHOUT GLASS | 2548 2300 1935 1034 1200 1438 | 2564 2300 1951 1034 1200 1438 | 2575 2300 1962 1034 1200 1438 |
| DOUBLE | 2548 2300 1935 1374 1800 2098 | 2564 2300 1951 1374 1800 2098 | 2575 2300 1962 1374 1800 2098 |

*A, B, C indicates price changing points. (A<B<C)
 ** Aluminum pattern not available for G01

COMFORT WITH MINIMAL DESIGN



A01

COLORS



TURIN PINE



CREA MOCHA

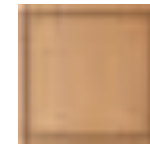



CREA RUSK



TEAK

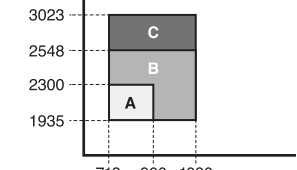
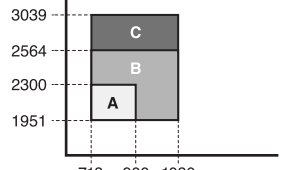
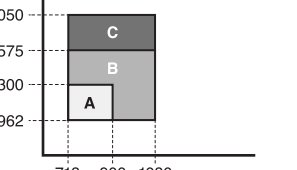
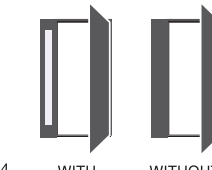
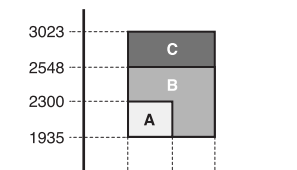
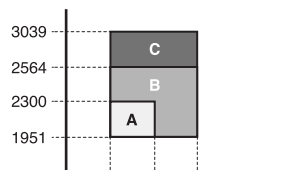
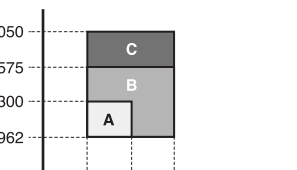

| Wood Pattern | In-Swing (no sill) | In-Swing | Out-Swing |
|---|---|---|---|
| SINGLE  |  |  |  |
| WITH SIDELIGHT Width of sidelight [SW] 1034 < W 1248 : SW = 304 1249 < W 1438 : SW = 346  |  |  |  |
| DOUBLE  | N/A | N/A | N/A |



| Aluminum Pattern | In-Swing (no sill) | In-Swing | Out-Swing |
|---|--------------------|----------|-----------|
| SINGLE  | N/A | N/A | N/A |
| WITH SIDELIGHT Width of sidelight [SW] 1034 < W 1248 : SW = 304 1249 < W 1438 : SW = 346  | N/A | N/A | N/A |
| DOUBLE  | N/A | N/A | N/A |

*A, B, C indicates price changing points. (A<B<C)

UNIQUE FEATURES

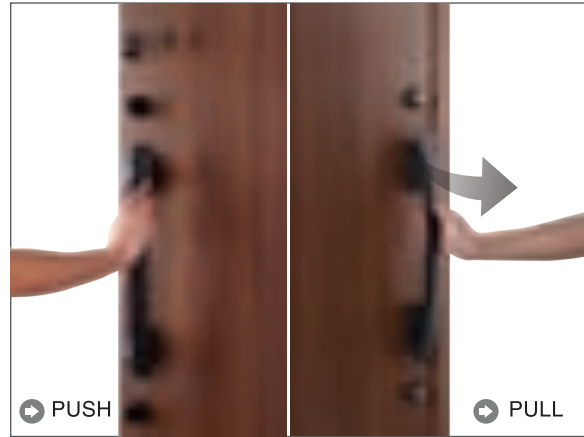

Push-Pull bar handle easy to operate. Just push or pull after unlock to open the door

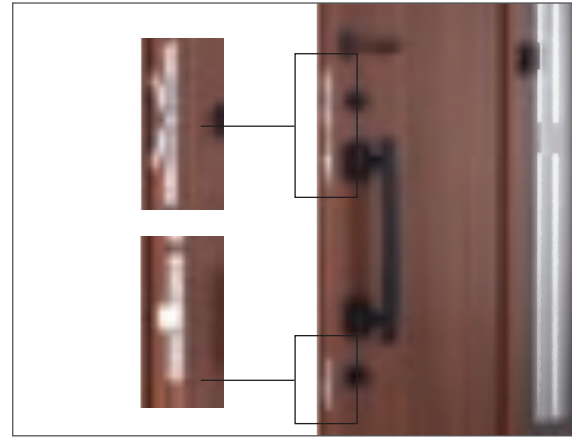

2 locks that control 3 latches



Remove inside key head to prevent from unlocking in case of burglary



Lock-unlock with ease with reversible key



Frame sealed with foam for watertight and anti-pinch



Door filled with insulation material for heat prevention and noise insulation



GIESTA AIRFLOW

A PERFECT SOLUTION FOR YOUR OWN COMFORT WITH MINIMAL DESIGN

High-performance wooden pattern steel door Giesta AIRFLOW series with integrated AIRFLOW window and insect screen is a perfect combination that keeps designing and housing comfort at heart. Giesta AIRFLOW allows air inside your house to circulate in and out all day to cool the living space, reduce humidity, remove unpleasant odor for serene ambience.

Invented to truly create soothing ambience and adding comfort to your home. Let the wind flow into the living space by opening ventilation panel without worrying as the AIRFLOW panel is wide enough to let the air flow in easily and too small to be entered from. Security is at its best with multi-lock function to lock and unlock by single lock at handle but securely lock 2 positions. Giesta AIRFLOW is Japanese Industrial Standards (JIS) certified and guaranteed with Japan's KIDS Design Award for its user-friendly and child safety design.

Provide passive ventilation environment



Complete air flow with security



Keep mosquito and pest away from your home



SIMPLE OPEN/ CLOSE OPERATION

AIRFLOW window is swing-in and can lock and unlock easily by using single lock handle to control 2 locks (Multi-lock). Open-close smoothly with high-performance hinge.

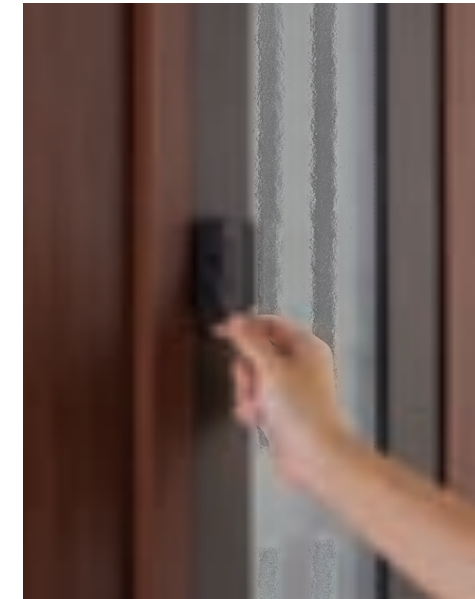

Lift lock handle to unlock

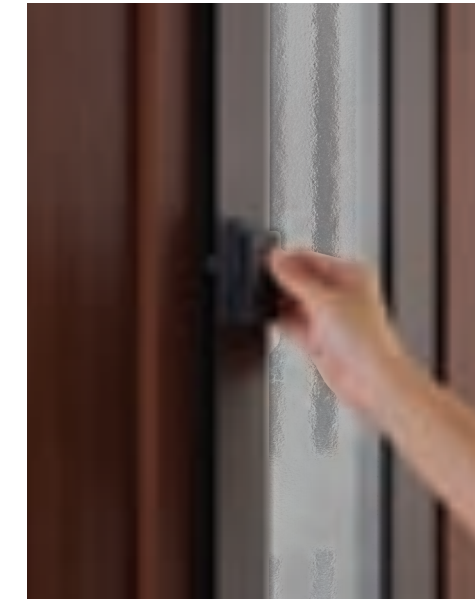





Pull down lock handle for ventilation

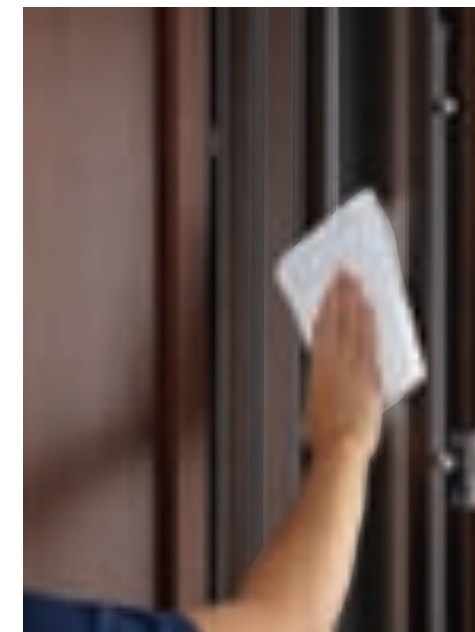

EASY TO CLEAN

Deep clean every corner without removing any part by spraying water from garden hose to insect screen from outside the room (please make sure that the AIRFLOW window and the door is completely closed)

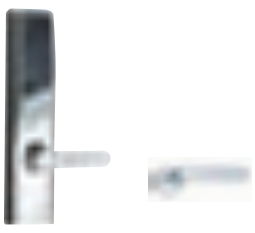

HANDLES

| | | | |
|--|--|--|---|
| <p>TYPE A</p>  <p>Outside Inside</p> | <p>TYPE F</p>  <p>Outside Inside</p> | <p>TYPE K</p>  <p>Outside & Inside</p> | <p>TYPE L</p>  <p>Outside & Inside</p> |
| <p>BLAST SILVER SILKY MATTE BLACK</p> | <p>BLAST SILVER SILKY MATTE BLACK</p> | <p>SATIN GOLD SILKY MATTE BLACK</p> | <p>BLAST SILVER SILKY MATTE BLACK</p> |
| <p>Apply for Out-Swing door only</p> | <p>Apply for Out-Swing door only</p> | <p>Apply for both Out-Swing and In-Swing door</p> | <p>Apply for both Out-Swing and In-Swing door</p> |



| | | |
|--|--|---|
| <p>DIGITAL LOCK</p>  <p>Outside Inside</p> | <p>DIGITAL LOCK</p>  <p>Outside Inside</p> | <p>DIGITAL LOCK</p>  <p>Outside Inside</p> |
| <p>SILVER BLACK</p> | <p>SILVER BLACK</p> | <p>SILVER BLACK</p> |
| <p>Apply for both Out-Swing and In-Swing door</p> | <p>Apply for Out-Swing door only</p> | <p>Apply for Out-Swing door only</p> |

- *Handle A and F
- Can be applied to In-Swing door as special order.
- Handle will be inside out.

ACCESSORIES

OUT-SWING DOOR

IN-SWING DOOR

| | | | |
|--|---|--|---|
| <p>DOOR CLOSER</p>  | <p>DOOR GUARD</p>  | <p>DOOR CLOSER</p>  | <p>DOOR GUARD</p>  |
| <p>AUTUMN BROWN SHINE GRAY</p> <p>NATURAL WHITE</p> | <p>BLAST SILVER SATIN GOLD</p> <p>SILKY MATTE BLACK</p> | <p>AUTUMN BROWN SHINE GRAY</p> | <p>SILVER</p> |
| <p>Aluminum</p> | <p>Aluminum</p> | <p>Aluminum</p> | <p>Aluminum</p> |

CYLINDER LOCK & KEY

| |
|---|
| <p>CYLINDER LOCK</p>  <p>Outside Inside</p> <p>Thumbturn Cylinder Construction Keys: 3 Owner Keys: 5</p> |
| <p>BLAST SILVER SATIN GOLD</p> <p>SILKY MATTE BLACK</p> |
| <p>Steel with resin coating</p> |



ALUMINUM EXTERIOR

FENCE & GATE EXTERIOR

FENCE & GATE is a perfect fencing choice for your residence. Our fence and gate solutions will enhance the look, feel and overall value of your property, while providing safety and security to your family.



FEATURES



ULTRA LIGHTWEIGHT



IMPACT TEST



EFFORTLESS MOVEMENT



LOW MAINTENANCE



ANTI-RUST DURABILITY

COLOUR



NATURAL SILVER
 SHINE GRAY
 AUTUMN BROWN
 NATURAL BLACK

LATTICE PATTERN

| SHAPE OF LATTICE | PITCH 60 | PITCH 80 | PITCH 100 | PITCH 120 | PITCH 140 |
|--|----------|----------|-----------|-----------|-----------|
| Sliding gate | | | | | |
| Folding gate Swing gate Fence | | | | | |

SLIDING GATE

| SINGLE SLIDING GATE | MINIMUM | MAXIMUM |
|-------------------------|----------|----------|
| Width (Opening width) | 2,100 mm | 5,600 mm |
| Height (Product height) | 1,200 mm | 2,000 mm |

*please see reference drawing for detail

| DOUBLE SLIDING GATE | MINIMUM | MAXIMUM |
|-------------------------|----------|----------|
| Width (Opening width) | 5,000 mm | 8,000 mm |
| Height (Product height) | 1,200 mm | 1,600 mm |

*please see reference drawing for detail



UNIQUE FEATURES



Square pipe design provides strength and durability

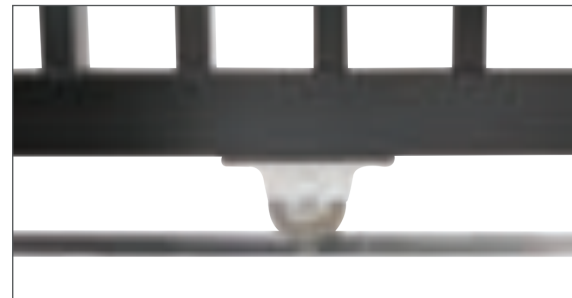

Durable stainless-steel wheel and track enable light and smooth gliding.

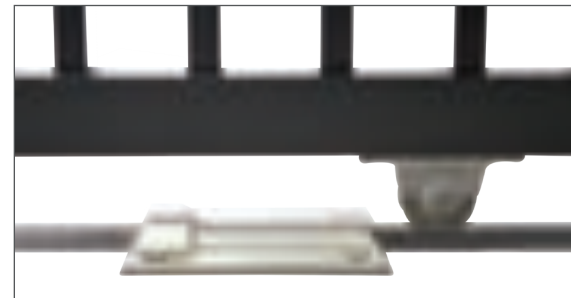

Wheel stopper ensures stop and hold when gate is closed



Panel guide for safety to hold panel when gliding for single panel type



Panel guide to hold both panels when gliding for safety for double panels type



FOLDING GATE

| 4 PANELS FOLDING GATE | MINIMUM | MAXIMUM |
|-------------------------|----------|----------|
| Width (Opening width) | 3,000 mm | 4,900 mm |
| Height (Product height) | 1,200 mm | 1,600 mm |

*please see reference drawing for detail

| 6 PANELS FOLDING GATE | MINIMUM | MAXIMUM |
|-------------------------|----------|----------|
| Width (Opening width) | 4,300 mm | 6,000 mm |
| Height (Product height) | 1,200 mm | 1,600 mm |

*please see reference drawing for detail



UNIQUE FEATURES



Hinges



Rollers



Drop rod

SWING GATE

| SINGLE SWING GATE | MINIMUM | MAXIMUM |
|-------------------------|----------|----------|
| Width (Opening width) | 600 mm | 1,100 mm |
| Height (Product height) | 1,200 mm | 1,600 mm |

*please see reference drawing for detail

| DOUBLE SWING GATE | MINIMUM | MAXIMUM |
|-------------------------|----------|----------|
| Width (Opening width) | 1,080 mm | 2,080 mm |
| Height (Product height) | 1,200 mm | 1,600 mm |

*please see reference drawing for detail

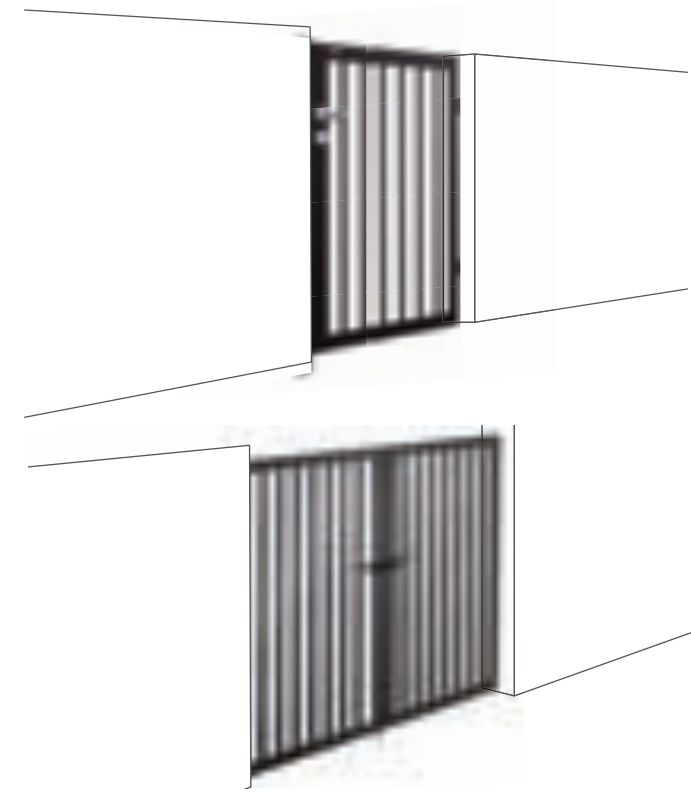

UNIQUE FEATURES



Hinges



Drop rod

FENCE

| | MINIMUM | MAXIMUM |
|-------------------------|---------|----------|
| Width (Opening width) | 500 mm | 2,000 mm |
| Height (Product height) | 600 mm | 1,200 mm |

*please see reference drawing for detail



UNIQUE FEATURES



Minimalist slim design yet sturdy. Wall anchor can be adjusted up to 7.5 mm



Straight and corner type fence jointer available. Adjustable from 90-180 degrees



Fence post with concrete surface mount with cover. Set-in-concrete type also available



LIXIL

Link to Good Living

LIXIL WINDOW SYSTEMS PRIVATE LIMITED

Factory & Showroom

Corp. Office: Plot No. 75, Sector 8, IMT Manesar,
Gurgaon, Haryana, India - 122050.,
Toll-free Number - 18001036855,
E-mail: tostemsales.lws@lixil.com

Showroom

TOSTEM Studio, Nyay Sagar, Plot No. F. S. No. 341,
CTS NO. 1272, 29, Jagat Vidya Marg,
MIG Colony, Bandra East,
Mumbai, Maharashtra - 400051

LIXIL Group Corporation

36F, Kasumigaseki Building,
3-2-5 Kasumigaseki, Chiyoda-ku,
Tokyo 100-6036, Japan
<http://global.LIXIL.co.jp/e>

LIXIL International Pte. Ltd.

8 Temasek Boulevard,
#12-03 Suntec Tower 3, Singapore 038988
Tel : +65 6690 4988 Fax : +65 6690 4986
<http://global.LIXIL.co.jp/e>

TOSTEM Thai Co., Ltd.

60/2 Soi Navanakorn 11,
Moo19 Phaholyothin Road,
Tambon Khlongnueng, Amphoe Khlongluang,
Pathumthani 12120, Thailand
Tel :+66 2529 0474-5 Fax : +66 2909 4487
<http://www.LIXIL.TOSTEM.co.th>

LIXIL Housing Products Manufacturing (Shanghai) Corporation

No14 Building Huabin
Industrial Park 99 Huajia Road
Songjiang Shanghai 201611

LIXIL (Thailand) Public Co., Ltd.

1/6 Moo 1, Phaholyothin Road K.M.32,
Klong Neung, Klong Luang,
Pathumthani 12120, Thailand
Tel : +66 2901 4455 Fax : +66 2901 4488
<http://www.LIXIL.co.th>

PT LIXIL Aluminium Indonesia

JV entity with Rodamas group Jl. Let. Jend. S.
Parman Kav. 32-34 Jakarta 11480, Indonesia
Tel :+62 21 2939 3388
Fax : +62 21 5367 4394
<http://global.LIXIL.co.jp/e>

LIXIL Vietnam Corporation

Charm Vit Tower, 18th Floor,
117 Tran Duy Hung, Hanoi, Vietnam
Tel : +84 4 3556 6639
Fax : +84 4 3556 6031
<http://www.INAX.com.vn>

LIXIL Philippines Ltd. Co.

18/F The Pearlbank Centre,
146 Valero Street, Salcedo Village,
Makati City 1227, Philippines
Tel : +63 2893 3113
Fax : +63 2893 9980
<http://americanstandard.com.ph>

LIXIL Taiwan

Rm. 701, 7F., No.225,
Nanjing E. Rd., Zhongshan, Dist.,
Taipei City 104, Taiwan

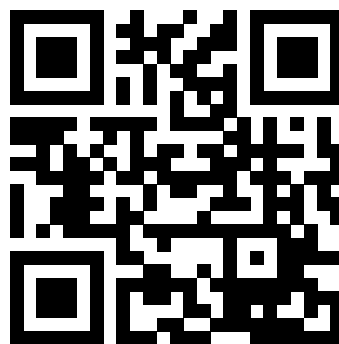

www.tostemindia.com

Channel Partner

ZACKLE

+91 9746 47 07 67